

**GENERAL APTITUDE****Q.No.1-5 Carry One Mark Each**

1. The current population of a city is 11,02,500. If it has been increasing at the rate of 5% per annum, what was its population 2 years ago?

(A) 9,92,500                      (B) 12,51,506                      (C) 9,95,006                      (D) 10,00,000

**Key: (D)**

2. Given below are two statements and two conclusions.

Statement 1: All purple are green.

Statement 2: All black are green.

Conclusion I: Some black are purple

Conclusion II: No black is purple

Based on the above statements and conclusions, which one of the following options is logically CORRECT?

(A) Either conclusion I or II is correct                      (B) Only conclusion I is correct  
(C) Both conclusion I and II are correct                      (D) Only conclusion II is correct

**Key: (A)**

3. Computers are ubiquitous. They are used to improve efficiency in almost all fields from agriculture to space exploration. Artificial intelligence (AI) is currently a hot topic. AI enables computers to learn, given enough training data. For humans, sitting in front of a computer for long hours can lead to health issues.

Which of the following can be deduced from the above passage?

- (i) Nowadays, computers are present in almost all places.  
(ii) Computers cannot be used for solving problems in engineering.  
(iii) For humans, there are both positive and negative effects of using computers.  
(iv) Artificial intelligence can be done without data.

(A) (ii) and (iv)                      (B) (i) and (iii)                      (C) (ii) and (iii)                      (D) (i), (iii) and (iv)

**Key: (B)**

4. Consider a square sheet of a side 1 unit. In the first step, it is cut along the main diagonal to get two triangles. In the next step, one of the cut triangles is revolved about its short edge to form a solid cone. The volume of the resulting cone, in cubic units, is \_\_\_\_\_.

(A)  $\frac{\pi}{3}$                       (B)  $\frac{2\pi}{3}$                       (C)  $3\pi$                       (D)  $\frac{3\pi}{2}$

**Key: (B)**

5. Consider the following sentences:

- (i) I woke up from sleep
- (ii) I woked up from sleep
- (iii) I was woken up from sleep
- (iv) I was wokened up from sleep

Which of the above sentences are grammatically CORRECT?

(A) (i) and (iv)              (B) (i) and (iii)              (C) (ii) and (iii)              (D) (i) and (ii)

**Key: (B)**

**Q.No.6-10 Carry Two Marks Each**

- 6.

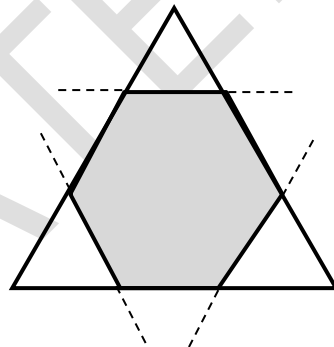

Corners are cut from an equilateral triangle to produce a regular convex hexagon as shown in the figure above.

The ratio of the area of the regular convex hexagon to the area of the original equilateral triangle is

(A) 4 : 5                      (B) 5 : 6                      (C) 3 : 4                      (D) 2 : 3

**Key: (D)**

7.

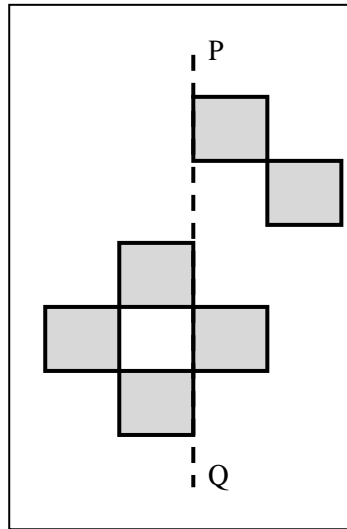

The least number of squares that must be added so that the line P-Q becomes the line of symmetry is \_\_\_\_\_.

- (A) 6                      (B) 3                      (C) 4                      (D) 7

**Key: (A)**

8.  $p$  and  $q$  are positive integers and  $\frac{p}{q} + \frac{q}{p} = 3$ , then,  $\frac{p^2}{q^2} + \frac{q^2}{p^2} =$

- (A) 3                      (B) 9                      (C) 7                      (D) 11

**Key: (C)**

9. Nostalgia is to anticipation as \_\_\_\_\_ is to \_\_\_\_\_

Which one of the following options maintains a similar logical relation in the above sentence?

- (A) Future, present                      (B) Past, future  
(C) Future, past                      (D) Present, past

**Key: (B)**

10.

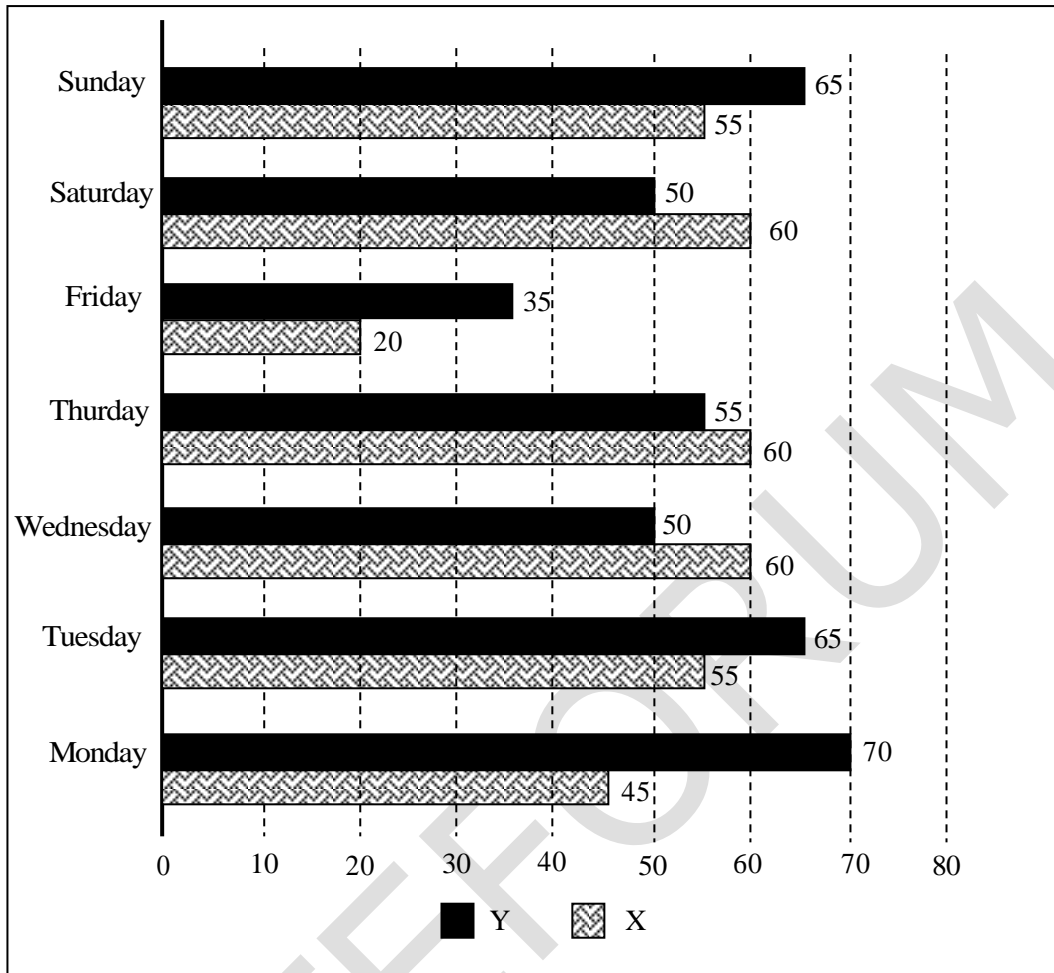

The number of minutes spent by two students, X and Y, exercising every day in a given week are shown in the bar chart above.

The number of days in the given week in which one of the students spent a minimum of 10% more than the other student, on a given day, is

- (A) 4                      (B) 7                      (C) 6                      (D) 5

**Key: (C)**

**ELECTRONICS AND COMMUNICATIONS**

**Q.No.1-25 Carry One Mark Each**

1. A box contains the following three coins.
- I. A fair coin with head on one face and tail on the other face.
  - II. A coin with heads on both the faces.
  - III. A coin with tails on both the faces.

A coin is picked randomly from the box and tossed. Out of the two remaining coins in the box, one coin is then picked randomly and tossed. If the first toss results in a head, the probability of getting a head in the second toss is

- (A)  $\frac{1}{2}$                       (B)  $\frac{2}{5}$                       (C)  $\frac{2}{3}$                       (D)  $\frac{1}{3}$

**Key: (D)**

2. Consider the integral

$$\oint_C \frac{\sin(x)}{x^2(x^2+4)} dx$$

Where C is a counter-clockwise oriented circle defined as  $|x - i| = 2$ . The value of the integral is

- (A)  $-\frac{\pi}{4} \sin(2i)$               (B)  $\frac{\pi}{4} \sin(2i)$               (C)  $\frac{\pi}{8} \sin(2i)$               (D)  $-\frac{\pi}{8} \sin(2i)$

**Key: (\*)**

**Sol:** C(curve) is  $|x - i| = 2$ .  $x^2(x^2 + 4) = 0$  gives  $x = 0, 2i, -2i$  are the singular points. Only  $x = 0, 2i$  lies inside C.

Now 
$$\frac{\sin x}{x^2(x^2+4)} = \frac{\sin x}{4x^2} - \frac{\sin x}{4(x^2+4)}$$

$$\therefore \oint_C \frac{\sin x}{x^2(x^2+4)} dx = \frac{1}{4} \oint_C \frac{\sin x}{(x-0)^2} dx - \frac{1}{4} \oint_C \frac{\left(\frac{\sin x}{x+2i}\right)}{x-2i} dx$$

$$= \frac{1}{4} \times \frac{2\pi i}{1!} \left[ \frac{d}{dx}(\sin x) \right]_{x=0} - \frac{1}{4} \times 2\pi i \left[ \frac{\sin x}{x+2i} \right]_{x=2i}$$

$$= \frac{\pi i}{2} - \frac{\pi i}{2} \times \frac{\sin(2i)}{4i}$$

( $\because$  Using Cauchy's integral formula and  $x^2 + 4 = (x + 2i)(x - 2i)$ )

$$= \frac{\pi i}{2} - \frac{\pi}{8} \sin(2i)$$

(No option matching).

3. An 8-bit unipolar (all analog output values are positive) digital-to-analog converter (DAC) has a full-scale voltage range from 0V to 7.68V. If the digital input code is 10010110 (the leftmost bit is MSB), then the analog output voltage of the DAC (rounded off to one decimal place) is \_\_\_\_\_ V.

**Key:** (45)

**Sol:** It is given that can 8-bit DAC have F.S.O 7.68V

We need to obtain analog output voltage for input (10010110).

$$\text{Resolution} = \frac{V_{\text{F.S.O}}}{2^n - 1} = \frac{7.68}{2^8 - 1} = 0.03011$$

Analog output = Resolution  $\times$  Decimal equivalent of  $(10010110)_2$

$$0.030 \times 150 = 4.5\text{V}$$

4. The switch in the circuit in the figure is in position P for a long time and then moved to position Q at time  $t = 0$ .

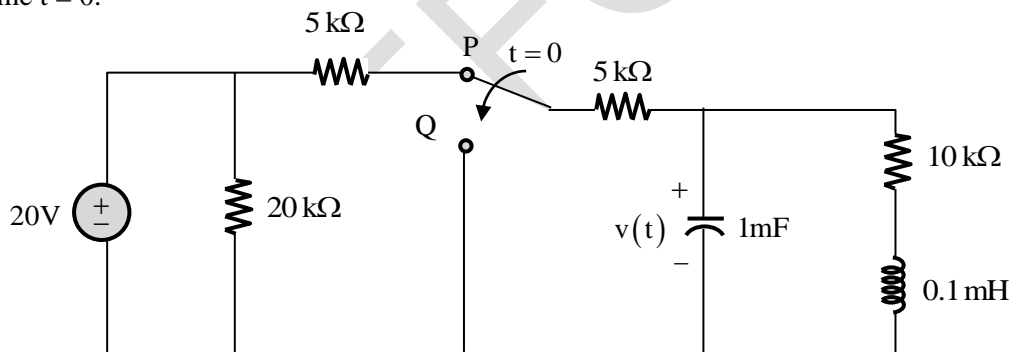

The value of  $\frac{dv(t)}{dt}$  at  $t = 0^+$  is

- (A) 3 V/s                      (B) -5 V/s                      (C) -3 V/s                      (D) 0 V/s

**Key:** (C)

**Sol:** The given network is

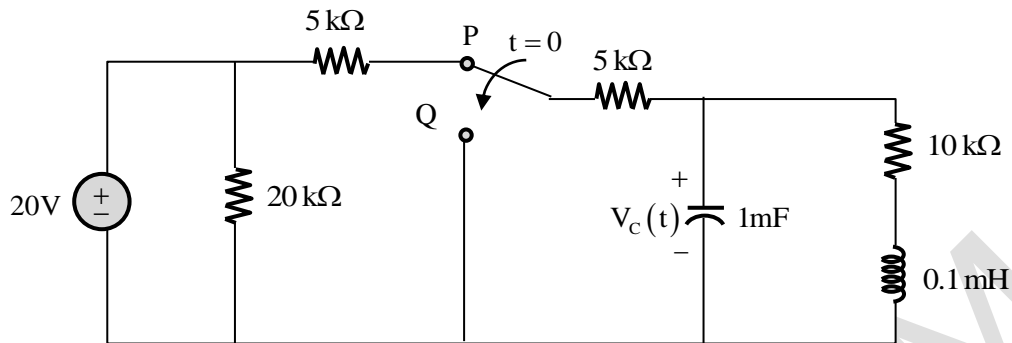

We need to obtain  $\left. \frac{dV_C(t)}{dt} \right|_{t=0^+}$

- at  $t = 0^-$  —
- Network in steady state
  - Capacitor open circuit
  - Inductor short circuit
  - Switch at P

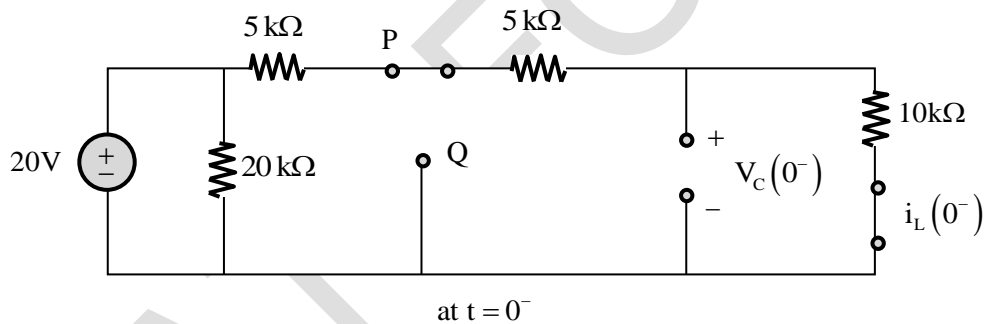

$$i_L(0^-) = \frac{20V}{(5+5+10)k\Omega} = \frac{20V}{20k\Omega} = 1mA$$

$$V_C(0^-) = (10k\Omega)[i_L(0^-)] = [10k\Omega][1mA] = 10V$$

- at  $t = 0^+$  —
- Switch at Q
  - Capacitor replaced by ideal voltage source of value  $V_C(0^-)$
  - Inductor replaced by ideal current source of value  $i_L(0^-)$

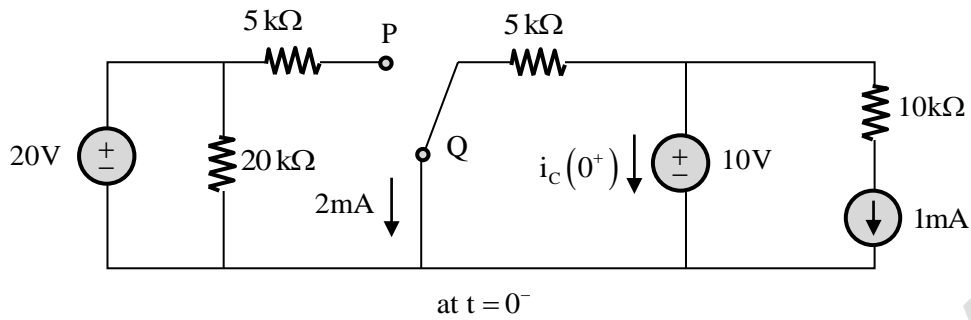

From the above circuit By KCL  $i_c(0^+) = -3 \text{ mA}$

$$i_c(t) = C \frac{dV_c(t)}{dt} \Rightarrow \frac{dV_c(t)}{dt} = \frac{i_c(t)}{C}$$

$$\Rightarrow \left. \frac{dV_c(t)}{dt} \right|_{t=0^+} = \frac{i_c(0^+)}{C} = \frac{-3 \text{ mA}}{1 \text{ mF}} = -3 \text{ V/sec}$$

5. Consider the circuit shown in the figure.

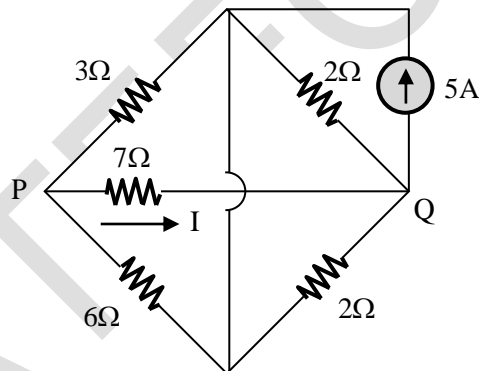

The current  $I$  flowing through the  $7\Omega$  resistor between  $P$  and  $Q$  (rounded off to one decimal place) is \_\_\_\_\_ A.

**Key: (0.5)**

**Sol:** In the following networks we need to find I

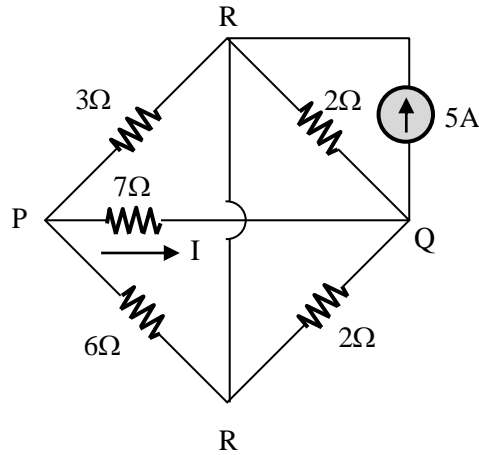

If we redraw the network it becomes

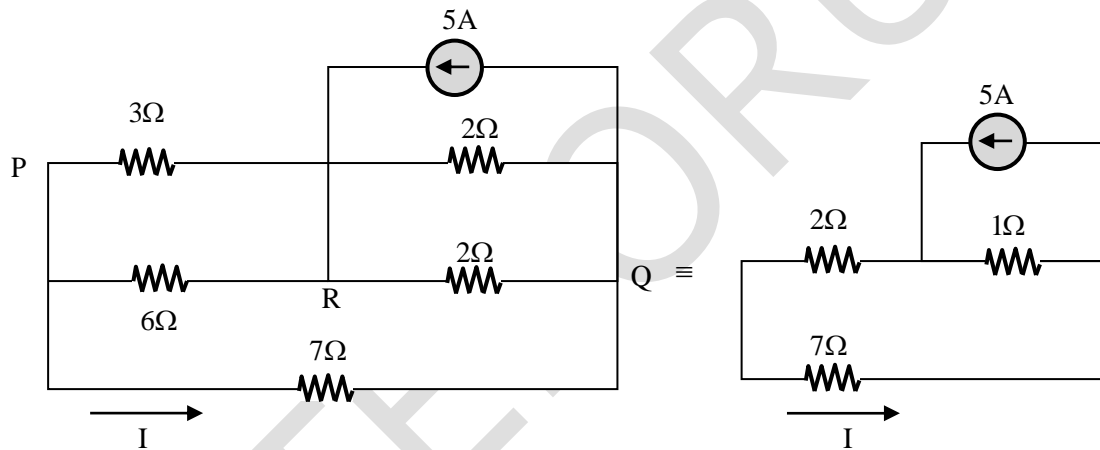

By current division rule  $I = \frac{5 \times 1}{1 + 2 + 7} = \frac{5}{10} = 0.5A$

6. Consider a carrier signal which is amplitude modulated by a single-tone sinusoidal message signal with a modulation index of 50%. If the carrier and one of the sidebands are suppressed in the modulated signal, the percentage of power saved (rounded off to one decimal place) is \_\_\_\_\_.

**Key:** (94.4)

**Sol:** Total power in amplitude modulated wave by a single tune sinusoidal signal

$$= P_c + P_c \frac{\mu^2}{4} + P_c \frac{\mu^2}{4}$$

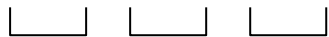

carrier sideband sideband

After suppressing carrier and one sideband

$$\text{Power} = \frac{P_c \mu^2}{4}$$

$$\Rightarrow \text{Savings in power} = P_C + P_C \frac{\mu^2}{4}$$

$$\text{Percentage of tower saved} = \frac{P_C + P_C \frac{\mu^2}{4}}{P_C + P_C \frac{\mu^2}{4} + P_C \frac{\mu^2}{4}} = \frac{4 + \mu^2}{2(2 + \mu^2)}$$

$$\text{For 50\% modulation this value is } \frac{4 + (0.5)^2}{2(2 + (0.5)^2)} = \frac{4.25}{4.5} = 94.4\%$$

7. For the circuit with an ideal OPAMP shown in the figure,  $V_{REF}$  is fixed.

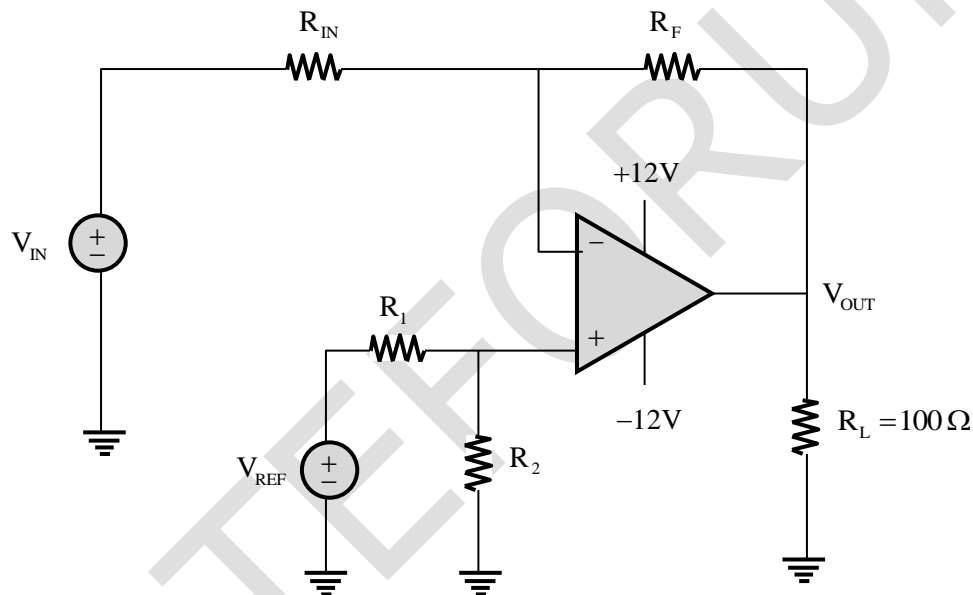

If  $V_{OUT} = 1$  volt for  $V_{IN} = 0.1$  volt and  $V_{OUT} = 6$  volt for  $V_{IN} = 1$  volt, where  $V_{OUT}$  is measured across  $R_L$  connected at the output of this OPAMP, the value of  $R_F/R_{IN}$  is

- (A) 5.555      (B) 2.860      (C) 3.825      (D) 3.285

**Key:** (A)

Sol:

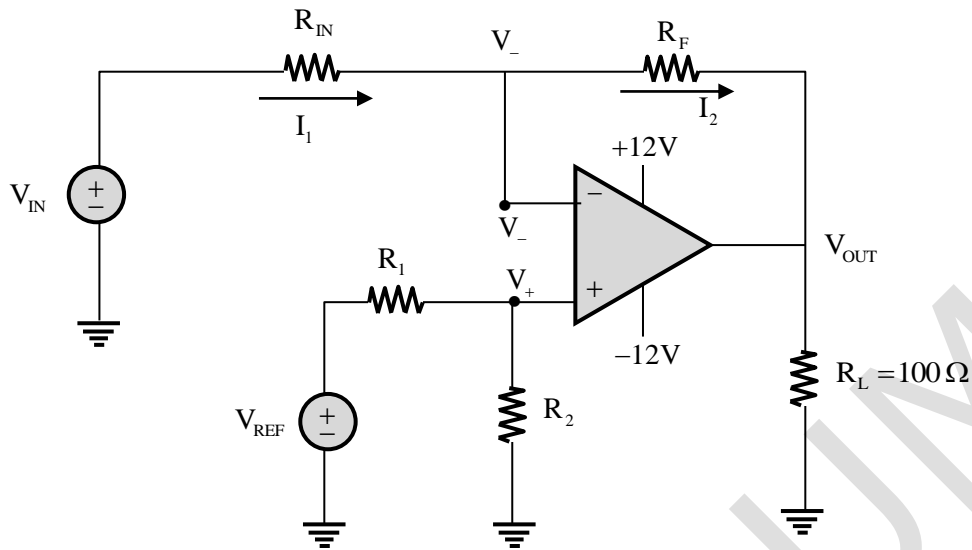

For ideal op-amp and virtual short concept

$$V_+ = V_- = \frac{R_2}{R_1 + R_2} \cdot V_{REF}$$

Apply KCL at node  $V_-$ , then

$$I_1 = I_2 \quad (\because \text{Input current of ideal op-amp is zero})$$

$$\frac{V_{IN} - V_-}{R_{IN}} = \frac{V_- - V_{OUT}}{R_F}$$

$$\frac{R_F}{R_{IN}} = \frac{V_- - V_{OUT}}{V_{IN} - V_-} \quad \dots(1)$$

If  $V_{OUT} = 1$  volt for  $V_{IN} = 0.1$  volt then equation (1) becomes

$$\frac{R_F}{R_{IN}} = \frac{V_- - 1}{0.1 - V_-} \quad \dots(2)$$

For  $V_{OUT} = 6$ V for  $V_{IN} = 1$  volt, then equation (1) becomes

$$\frac{R_F}{R_{IN}} = \frac{V_- - 6}{1 - V_-} \quad \dots(3)$$

Compare equation (2) and (3)

$$\frac{V_- - 1}{0.1 - V_-} = \frac{V_- - 6}{1 - V_-}$$

$$V_- = V_+ = -0.097 \text{ volt}$$

Substitute the value of  $V_-$  in equation (3), then

$$\frac{R_F}{R_{IN}} = \frac{-0.097 - 6}{1 - (-0.097)} = -5.55$$

$$\therefore \frac{R_F}{R_{IN}} = 5.55 \leftarrow \text{only magnitude should be considered.}$$

8. A circuit with an ideal OPAMP is shown in the figure. A pulse  $V_{IN}$  of 20 ms duration is applied to the input. The capacitors are initially unchanged.

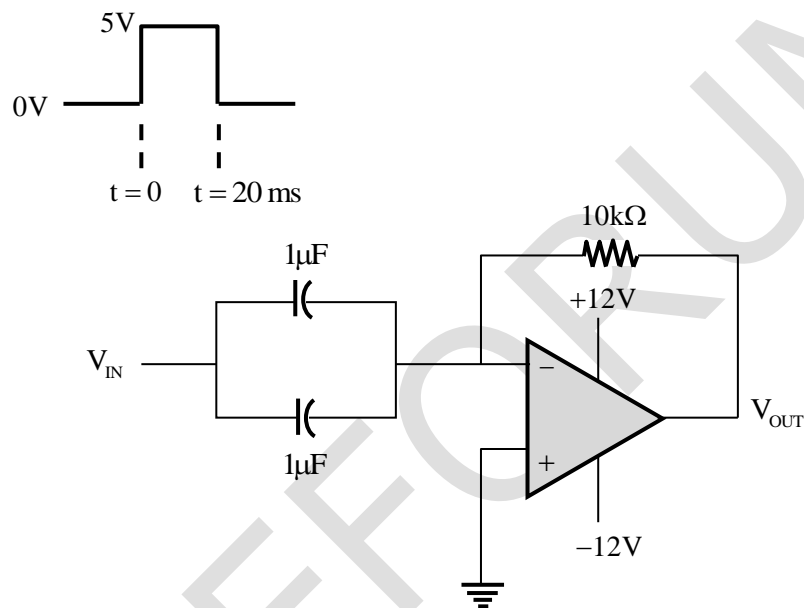

The output voltage  $V_{OUT}$  of this circuit at  $t = 0^+$  (in integer) is \_\_\_\_\_ V.

**Key:** (-12)

**Sol:**

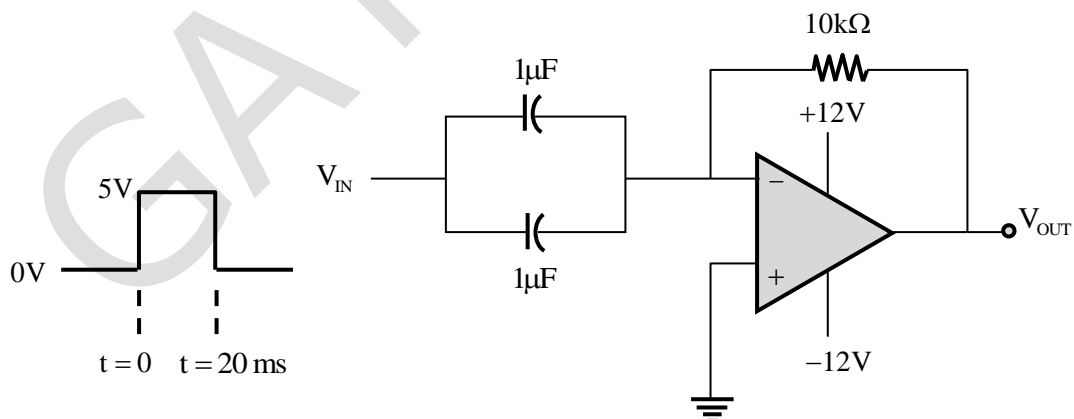

Initially capacitors are uncharged, therefore  $dV_{C1} = V_{C2} = 0$  means capacitors will behave as short circuit.

Capacitors doesn't allow sudden change in voltage, so at  $t = 0^+$ ,  $V_{C1} = V_{C2} = 0V$

So, the voltage at  $V_- = 5V$  at  $t = 0^+$  and  $V_+ = 0V$

$V_- > V_+ \Rightarrow V_+ - V_- < 0V$ , so op-amp will produce, saturated negative output voltage.

Hence  $V_{out} = -12V$

9. The energy band diagram of a p-type semiconductor bar of length  $L$  under equilibrium condition (i.e., the Fermi energy level  $E_F$  is constant) is shown in the figure. The valance band  $E_V$  is sloped since doping is non-uniform along the bar. The difference between the energy levels of the valance band at the two edges of the bar is  $\Delta$ .

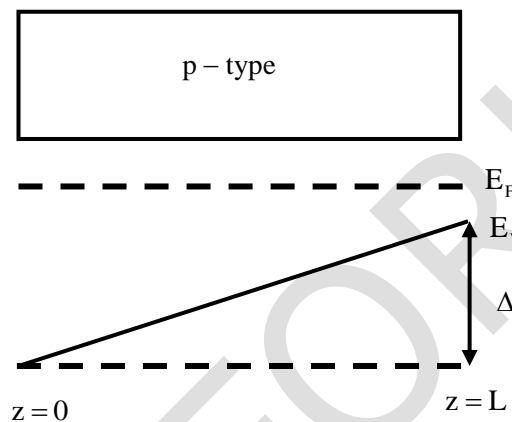

If the charge of an electron is  $q$ , then the magnitude of the electric field developed inside this semiconductor bar is

- (A)  $\frac{2\Delta}{qL}$  (B)  $\frac{\Delta}{2qL}$  (C)  $\frac{\Delta}{qL}$  (D)  $\frac{3\Delta}{2qL}$

**Key:** (C)

**Sol:**

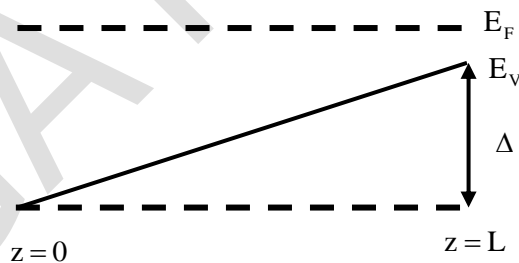

This is the case of non-uniform doping so the relationship between the electric field and slope of energy-level is given by

$$|E_x| = \left| \frac{1}{q} \frac{dE_v}{dx} \right| \Rightarrow E_x = \frac{1}{q} \left( \frac{\Delta - 0}{L - 0} \right)$$

$$\therefore E = \frac{1}{q} \frac{\Delta}{L}$$

10. A standard air-filled rectangular waveguide with dimensions  $a = 8$  cm,  $b = 4$  cm, operates at 3.4 GHz. For the dominant mode of wave propagation, the phase velocity of the signal is  $v_p$ . The value (rounded off to two decimal places) of  $v_p/c$ , where  $c$  denotes the velocity of light, is \_\_\_\_\_.

**Key:** (1.199)

**Sol:** We know  $v_p = \frac{C}{\sqrt{1 - \left(\frac{f_c}{f}\right)^2}}$ ,  $f = 3.4$  GHz

Since  $a > b$ , dominant mode  $f_{c10} = \frac{C}{2a} = \frac{3 \times 10^8}{2 \times 8 \times 10^{-2}} = 1.875$  GHz

$$\Rightarrow \frac{v_p}{C} = \frac{1}{\sqrt{1 - \left(\frac{1.875}{3.4}\right)^2}} = \frac{1}{\sqrt{0.695}} = 1.199$$

11. Consider a polar non-return to zero (NRZ) waveform, using +2V and -2V for representing binary '1' and '0' respectively, is transmitted in the presence of additive zero-mean white Gaussian noise with variance  $0.4$  V<sup>2</sup>. If the a priori probability of transmission of a binary '1' is 0.4, the optimum threshold voltage for a maximum a posteriori (MAP) receiver (rounded off to two decimal places) is \_\_\_\_\_ V.

**Key:** (0.04)

**Sol:** Optimum threshold for a maximum a posteriori (MAP) receiver under AWGN channel is

$$\lambda = \frac{\sigma^2}{a_1 - a_2} \ln \frac{P_0}{P_1}, \quad a_1 = 2, a_2 = -2$$

$$= \frac{0.4}{2 - (-2)} \ln \left( \frac{0.6}{0.4} \right) = 0.1 \times 0.4 = 0.04$$

12. The exponential Fourier series representation of a continuous-time periodic signal  $x(t)$  is defined as

$$x(t) = \sum_{k=-\infty}^{\infty} a_k e^{jk\omega_0 t}$$

Where  $\omega_0$  is the fundamental angular frequency of  $x(t)$  and the coefficient of the series are  $a_k$ . The following information is given about  $x(t)$  and  $a_k$ .

- I.  $x(t)$  a real and even, having a fundamental period of 6
- II. The average value of  $x(t)$  is 2
- III.  $a_k = \begin{cases} k, & 1 \leq k \leq 3 \\ 0, & k > 3 \end{cases}$

The average power of the signal  $x(t)$  (rounded off to one decimal place) is \_\_\_\_\_.

**Key:** (32)

**Sol:** For a periodic signal  $x(t)$  is given that

- Its period is 6, it is real, even.
- Average value of  $x(t)$  is 2 i.e.,  $a_0 = 2$ .

$$\bullet \quad a_k = \begin{cases} k; & 1 \leq k \leq 3 \\ 0; & k > 3 \end{cases} \Rightarrow \begin{matrix} a_1 = 1 \\ a_2 = 2 \\ a_3 = 3 \end{matrix}$$

We need to compute its average power.

By Parseval's theorem

$$\begin{aligned} P &= \sum_{k=-\infty}^{\infty} |a_k|^2 = a_0^2 + 2 \sum_{k=1}^{\infty} |a_k|^2 \\ &= a_0^2 + 2 \sum_{k=1}^3 |a_k|^2 \quad (\because a_k = 0 \text{ for } k > 3) \\ &= a_0^2 + 2[|a_1|^2 + |a_2|^2 + |a_3|^2] \\ &= 2^2 + 2[1^2 + 2^2 + 3^2] \\ &= 4 + 2[1 + 4 + 9] \\ &= 4 + 28 = 32 \end{aligned}$$

Note: since  $x(t)$  is real and even its magnitude spectrum  $|a_k|$  will be real and even, it means,

$$\begin{aligned} \text{If } |a_1| = 1 \text{ then } |a_{-1}| &= 1 \\ |a_2| = 2 \text{ then } |a_{-2}| &= 2 \text{ etc.} \end{aligned}$$

- 13.** For a vector field  $D = \rho \cos^2 \phi a_\rho + z^2 \sin^2 \phi a_\phi$  in a cylindrical coordinate system  $(\rho, \phi, z)$  with unit vectors  $a_\rho, a_\phi$  and  $a_z$ , the net flux of  $D$  leaving the closed surface of the cylinder ( $\rho = 3, 0 \leq z \leq 2$ ) (rounded off to two decimal places) is \_\_\_\_\_.

**Key:** (56.55)

**Sol:** Let  $D = (\rho \cos^2 \phi) a_\rho + (z^2 \sin^2 \phi) a_\phi$  be a vector in cylindrical system then

$$\text{div}(D) = \frac{1}{\rho} \left\{ \frac{\partial}{\partial \rho} (\rho D_\rho) + \frac{\partial}{\partial \phi} (D_\phi) + \frac{\partial}{\partial z} (D_z) \right\}$$

Where  $D_\rho = \rho \cos^2 \phi$ ;  $D_\phi = z^2 \sin^2 \phi$ ;  $D_z = 0$

$$\Rightarrow \text{div}(D) = \frac{1}{\rho} \left\{ 2\rho \cos^2 \phi + 2z^2 \sin \phi \cos \phi \right\} = (1 + \cos 2\phi) + \frac{z^2 \sin 2\phi}{\rho}$$

$\therefore$  Electric (net) flux of  $D$  leaving the closed surface of the cylinder is

$$\oiint_S \mathbf{D} \cdot d\mathbf{s} = \iiint_V \text{div}(\mathbf{D}) dV \quad (\text{Using Gauss divergence theorem})$$

$$= \int_{\rho=0}^3 \int_{\phi=0}^{2\pi} \int_{z=0}^2 (1 + \cos 2\phi) \rho d\rho d\phi dz + \int_{\rho=0}^3 \int_{\phi=0}^{2\pi} \int_{z=0}^2 \left( \frac{z^2 \sin 2\phi}{\rho} \right)$$

$$\left( \begin{array}{l} \because dV = \rho d\rho d\phi dz \text{ and '}\rho\text{' limits : 0 to 3,} \\ \phi \text{ limits : 0 to } 2\pi \\ z \text{ limits : 0 to 2} \end{array} \right)$$

$$= \left( \frac{\rho^2}{2} \right)_0^3 \left( \phi + \frac{\sin 2\phi}{2} \right)_0^{2\pi} \times (z)_0^2 + (\ell n \rho)_0^3 \times \left( \frac{-\cos 2\phi}{2} \right)_0^{2\pi} \times \left( \frac{z^3}{3} \right)_0^2$$

$$= \left( \frac{9}{2} \right) \times (2\pi + 0) \times 2 + 0 = 18\pi \approx 56.55$$

14. Consider a real-valued base-band signal  $x(t)$ , band limited to 10 kHz. The Nyquist rate for the signal  $y(t) = x(t)x\left(1 + \frac{t}{2}\right)$  is

(A) 15 kHz                      (B) 30 kHz                      (C) 60 kHz                      (D) 20 kHz

**Key:** (B)

**Sol:** It is given that  $x(t)$  is band limited to 10 kHz, we need to compute Nyquist rate of  $y(t) = x(t)x\left(1 + \frac{t}{2}\right)$

$x(t)$  having maximum frequency  $f_{m_1} = 10$  kHz

$x\left(\frac{t}{2}\right)$  having maximum frequency  $f_{m_2} = 5$  kHz

$x\left(\frac{t+2}{2}\right) = x\left(\frac{t}{2} + 1\right) = x\left(1 + \frac{t}{2}\right)$  will have maximum frequency same as  $x\left(\frac{t}{2}\right)$  i.e., 5 kHz, since time shifting does not affect the frequency limit of original signal.

$x(t).x\left(1 + \frac{t}{2}\right)$  will have maximum frequency  $f_{m_1} + f_{m_2} = 10 + 5 = 15$  kHz

Since in frequency domain it will lead to convolution and in convolution upper limit is sum of upper limit.

Nyquist rate =  $2(f_{m_1} + f_{m_2}) = 2 \times 15 = 30$  kHz

15. Two continuous random variables X and Y are related as

$$Y = 2X + 3$$

Let  $\sigma_X^2$  and  $\sigma_Y^2$  denote the variances of X and Y, respectively. The variances are related as

(A)  $\sigma_Y^2 = 5\sigma_X^2$       (B)  $\sigma_Y^2 = 2\sigma_X^2$       (C)  $\sigma_Y^2 = 25\sigma_X^2$       (D)  $\sigma_Y^2 = 4\sigma_X^2$

**Key:** (D)

**Sol:** Given,  $Y = 2X + 3$

$$\begin{aligned} \text{Var}(Y) &= E(Y^2) - (E(Y))^2 \\ &= E[(2X+3)^2] - [E(2X+3)]^2 \\ &= 4[E(X^2) - (E(X))^2] \\ \sigma_Y^2 &= 4\sigma_X^2 \end{aligned}$$

16. For the transistor  $M_1$  in the circuit shown in the figure,  $\mu_n C_{ox} = 100 \mu\text{A}/\text{V}^2$  and  $(W/L) = 10$ , where  $\mu_n$  is the mobility of electron,  $C_{ox}$  is the oxide capacitance per unit area, W is the width and L is the length.

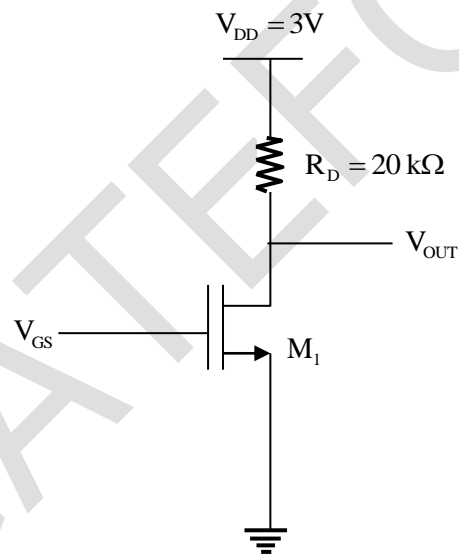

The channel length modulation coefficient is ignored. If the gate-to-source voltage  $V_{GS}$  is 1V to keep the transistor at the edge of saturation, then the threshold voltage of the transistor (rounded off to one decimal place) is \_\_\_\_\_ V.

**Key: (0.55)**

**Sol:**  $I_{D(sat)} = \frac{1}{2} \mu_n C_{ox} \frac{W}{L} (V_{GS} - V_T)^2$

$$\frac{3-1}{20} \text{mA} = \frac{1}{2} \times 100 \mu\text{A}/\text{V}^2 \times 10 (V_{GS} - V_T)^2$$

$$\frac{1}{10} \text{mA} = \frac{1}{2} \times \frac{\text{mA}}{\text{V}^2} \times (1 - V_T)^2$$

$$(1 - V_T)^2 = \frac{2}{10} \text{V}^2 = \frac{1}{5} \text{V}^2$$

$$1 - V_T = \pm 0.447 \text{ volt}$$

$$1 - V_T = +0.447 \text{ volt}$$

$$V_T = 1 - 0.447 \text{ volt} = 0.552 \text{ volt}$$

$$1 - V_T = -0.447 \text{ volt}$$

$$V_T = 1 + 0.447 = 1.447 \text{ volt}$$

As per the characteristics of MOS transition  $V_G - V_T > 0V$

So,  $V_T = 0.55 \text{ volt}$  is accepted value.

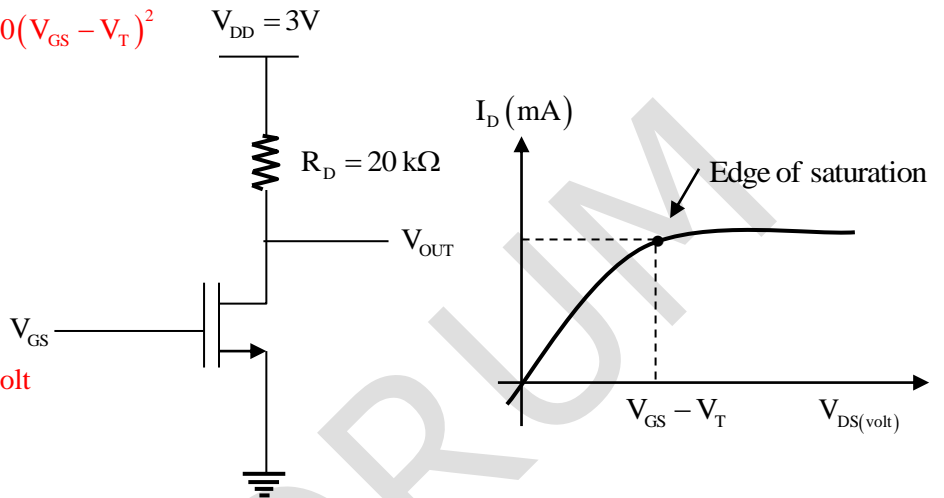

17. An antenna with a directive gain of 6 dB is radiating a total power of 16 kW. The amplitude of the electric field in free space at a distance of 8 km from the antenna in the direction of 6 dB gain (rounded off to three decimal places) is \_\_\_\_\_ V/m.

**Key: (0.245)**

**Sol:** Since antenna gain is 6dB

Total effective Isentropic, Radiated power

$$\text{EIRP} = 16 \times 4 = 64 \text{ kW}$$

$$\text{Power density at a distance of 8 km} = \frac{64 \times 10^3}{4\pi \times (8000)^2}$$

$$\Rightarrow \frac{|E_o|^2}{2 \times 120\pi} = \frac{64 \times 10^3}{4\pi \times (8000)^2}$$

$$\Rightarrow E_o = \sqrt{\frac{64 \times 60 \times 10^3}{8000 \times 8000}} = 0.245 \text{ V/m}$$

18. A message signal having peak-to-peak value of 2V, root mean square value of 0.1V and bandwidth of 5 kHz is sampled and fed to a pulse code modulation (PCM) system that uses a uniform quantizer. The PCM output is transmitted over a channel that can support a maximum transmission rate of 50 kbps. Assuming that the quantization error is uniformly distributed, the maximum signal to quantization noise ratio that can be obtained by the PCM system (rounded off to two decimal places) is \_\_\_\_\_.

**Key:** (30.72)

**Sol:** Signal to quantization noise ratio  $(SNR)_q = \frac{\text{signal power}}{\text{Quantization noise power}}$

$$\text{Signal power} = (\text{RMS})^2 = (0.1)^2 = 0.01$$

$$\text{Quantization step size } \Delta = \frac{x(t)_{\max} - x(t)_{\min}}{L} = \frac{Z}{L}$$

$$\text{Data rate} = n.F_s$$

Where 'n' in number of encoder bits.

$F_s$  is sampling frequency.

It is given that  $n.F_s \leq 50 \times 10^3$  bits per second

$$\text{Minimum } F_s = 2 \times 5 \text{ kHz} = 10 \text{ kHz}$$

$$\Rightarrow n \times 10 \times 10^3 \leq 50 \times 10^3$$

$$\Rightarrow n \leq 5, \text{ taking maximum } n = 5$$

Quantization step size  $\Delta = \frac{2}{2^5}$ , quantization noise power =  $\frac{\Delta^2}{12}$  to maximum  $(SNR)_q$ , quantization noise power should be minimized.

$$\Rightarrow (SNR)_{q \max} = \frac{(0.01)}{\frac{(1/24)^2}{12}} = \frac{0.01 \times 12}{\left(\frac{1}{16}\right)^2} = 30.72$$

19. In a high school having equal number of boy students and girl students, 75% of the students study science and the remaining 25% students study Commerce. Commerce students are two times more likely to be a boy than are Science students. The amount of information gained in knowing that a randomly selected girl student studies Commerce (rounded off to three decimal places) is \_\_\_\_\_ bits.

**Key:** (3.322)

20. For a unit step input  $u[n]$ , a discrete-time LTI system produces an output signal  $(2\delta[n+1] + \delta[n] + \delta[n-1])$ . Let  $y[n]$  be the output of the system for an input  $\left(\left(\frac{1}{2}\right)^n u[n]\right)$ . The value of  $y[0]$  is \_\_\_\_\_.

**Key:** (0)

**Sol:** It is given that for unit step input  $u(n)$ , the output is  $2\delta(n+1) + \delta(n) + \delta(n-1)$ . We need to obtain the system response for input  $\left(\frac{1}{2}\right)^n u(n)$ .

$$s(n) = 2\delta(n+1) + \delta(n) + \delta(n-1) \quad [s(n) : \text{step response}]$$

$$h(n) = s(n) - s(n-1) \quad (h(n) : \text{impulse response})$$

$$= 2\delta(n+1) + \delta(n) + \delta(n-1) - [2\delta[(n-1)+1] + \delta(n-1) + \delta[(n-1)-1]]$$

$$= 2\delta(n+1) + \delta(n) + \delta(n-1) - 2\delta(n) - \delta(n-1) - \delta(n-2)$$

$$= 2\delta(n+1) - \delta(n) - \delta(n-2)$$

When the input is  $x(n) = \left(\frac{1}{2}\right)^n u(n)$  then its response is

$$y(n) = x(n) * h(n)$$

$$= \left[\left(\frac{1}{2}\right)^n u(n)\right] * [2\delta(n+1) - \delta(n) - \delta(n-2)]$$

$$= \left[\left(\frac{1}{2}\right)^n u(n) * 2\delta(n+1)\right] - \left[\left(\frac{1}{2}\right)^n u(n) * \delta(n)\right] - \left[\left(\frac{1}{2}\right)^n u(n) * \delta(n-2)\right]$$

$$= 2\left(\frac{1}{2}\right)^{n+1} u(n+1) - \left(\frac{1}{2}\right)^n u(n) - \left(\frac{1}{2}\right)^{n-2} u(n-2)$$

$$y(0) = 2\left(\frac{1}{2}\right)^1 u(1) - \left(\frac{1}{2}\right)^0 u(0) - \left(\frac{1}{2}\right)^{-1} u(-2)$$

$$= \left(2 \times \frac{1}{2} \times 1\right) - (1 \times 1) - \left[\left(\frac{1}{2}\right)^{-2} \times 0\right] = 1 - 1 - 0 = 0$$

21. In the circuit shown in the figure, the transistors  $M_1$  and  $M_2$  are operating in saturation. The channel length modulation coefficients of both the transistors are non-zero. The transconductance of the MOSFETs  $M_1$  and  $M_2$  are  $g_{m1}$  and  $g_{m2}$ , respectively, and the internal resistance of the MOSFETs  $M_1$  and  $M_2$  are  $r_{o1}$  and  $r_{o2}$ , respectively.

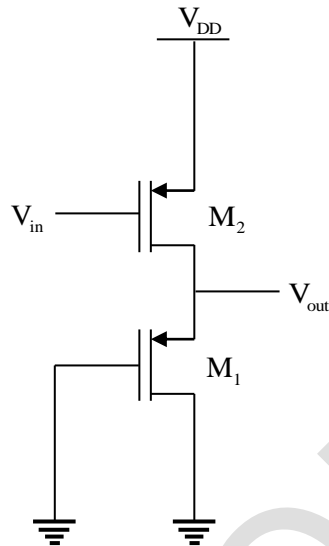

Ignoring the body effect, the ac small signal voltage gain  $\left(\frac{\partial V_{out}}{\partial V_{in}}\right)$  of the circuit is

- (A)  $-g_{m2} \left( \frac{1}{g_{m1}} \parallel r_{o2} \right)$                       (B)  $-g_{m2} (r_{o1} \parallel r_{o2})$   
 (C)  $-g_{m2} \left( \frac{1}{g_{m1}} \parallel r_{o1} \parallel r_{o2} \right)$                       (D)  $-g_{m1} \left( \frac{1}{g_{m2}} \parallel r_{o1} \parallel r_{o2} \right)$

**Key:** (C)

**Sol:**

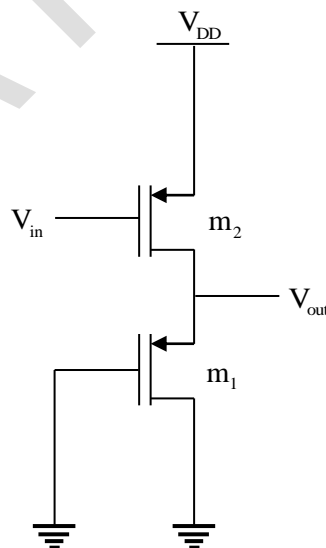

A. C equivalent of  $M_1$  transistor ( $\lambda \neq 0$ )

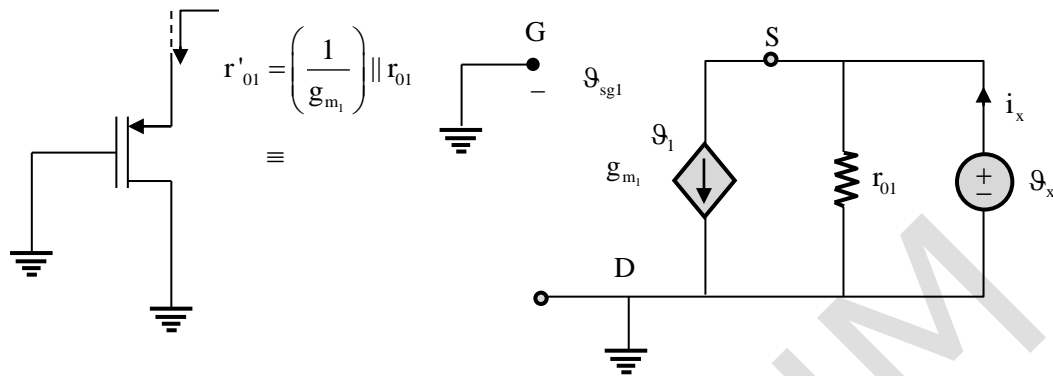

Apply KCL at source node

$$\begin{aligned} i_x &= \frac{v_x}{r_{o1}} + g_{m1} v_{sg1} \\ &= \frac{v_x}{r_{o1}} + g_{m1} v_x \quad (\because v_{sg1} = v_x) \\ &= \left( \frac{1}{r_{o1}} + g_{m1} \right) v_x \end{aligned}$$

$$r'_{o1} = \frac{v_x}{i_x} = \frac{1}{\frac{1}{r_{o1}} + g_{m1}} = \frac{1}{g_{m1}} \parallel r_{o1}$$

a.c equivalent of complete amplifier circuit

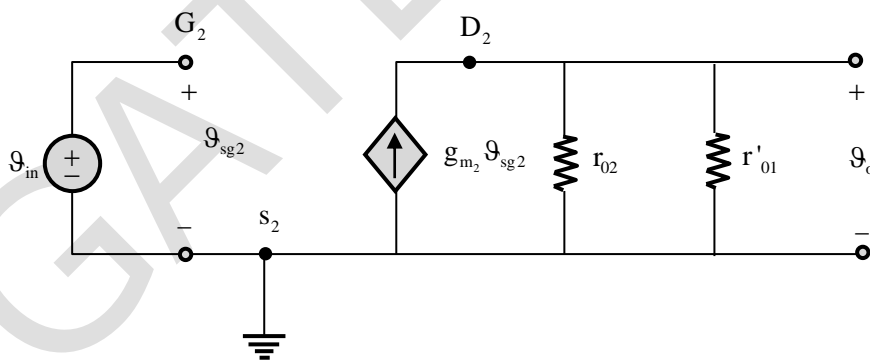

Apply KCL at output node

$$\begin{aligned} g_{m2} v_{sg2} &= \frac{v_o}{r_{o2}} + \frac{v_o}{r'_{o1}} \\ g_{m2} v_{sg2} &= v_o \left( \frac{1}{r_{o2}} + \frac{1}{r'_{o1}} \right) \end{aligned}$$

$$g_{m_2} g_{sg2} = g_o \frac{1}{r_{eq}}$$

$$g_{sg2} = g_{s2} - g_{g2} = 0 - g_{g2} = g_{in} \quad (\because V_{in} = g_{g2})$$

$$-g_{m_2} g_{in} = g_o r_{eq}$$

$$\frac{g_o}{g_{in}} = -g_{m_2} r_{eq} = -g_{m_2} (r_{o2} \parallel r'_{o1}) = -g_{m_2} (r'_{o1} \parallel r_{o2})$$

$$A_g = \frac{\partial g_o}{\partial g_{in}} = -g_{m_2} \left( \frac{1}{g_{m_1}} \parallel r_{o1} \parallel r_{o2} \right)$$

22. The propagation delays of the XOR gate, AND gate and multiplexer (MUX) in the circuit shown in the figure are 4ns, 2ns and 1 ns, respectively.

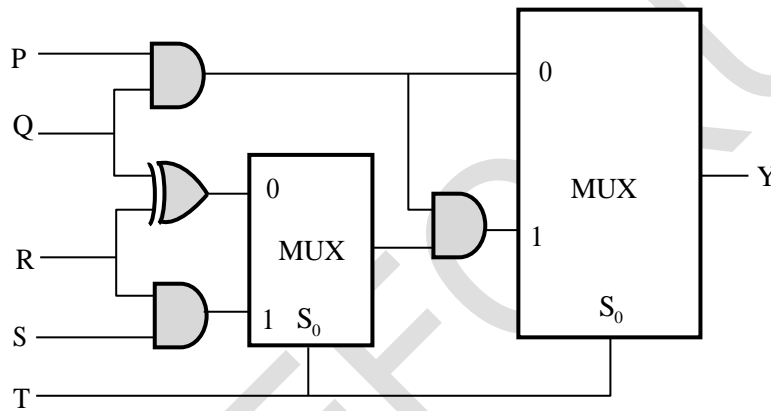

If all the inputs P, Q, R, S and T are applied simultaneously and held constant, the maximum propagation delay of the circuit is

- (A) 3 ns                      (B) 6 ns                      (C) 5 ns                      (D) 7 ns

**Key:** (B)

**Sol:** The given combination circuit is

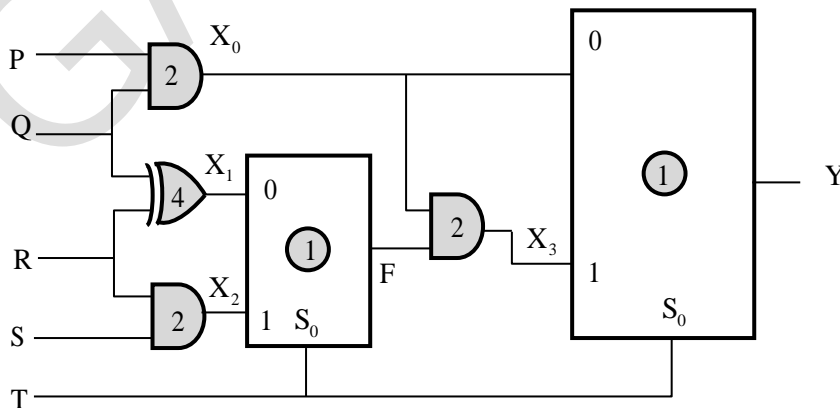

When  $T = 0$ , to get output only signal  $x_0$  is essential for second MUX, so the delay involved in this case is  $2n$  sec for  $x_0$ , MUX delay 1 nsec, total  $2 + 1 = 3$  nsec.

When  $T = 1$ , to get output Y we need  $X_2$  and  $X_3$ .  $X_2$  will be available at 2nsec (delay of AND gate)

F will be available after 1 n-sec of  $X_2$   $2 + 1 = 3$ nsec (i.e., delay of MUX with  $X_2$ ),

$X_3$  will available after 2 nsec of F i.e.,  $3 + 2 = 5$  nsec

Y will be available after 1 nsec of  $X_3$  i.e.,  $5 + 1 = 6$  nsec

When  $T = 0$ , we get Y at 3 nsec

$T = 1$ , we get Y at 6 nsec

Worst case delay is 6nsec

23. A digital transmission system uses a (7, 4) systematic linear Hamming code for transmitting data over a noisy channel. If three of the message-codeword pairs in this code ( $m_i : c_i$ ), where  $c_i$  is the codeword corresponding to the  $i^{\text{th}}$  message  $m_i$ , are known to be (1100; 0101100), (1110; 0011110) and (0110; 1000110), then which of the following is a **valid codeword** in this code?

(A) 1101001                      (B) 0110100                      (C) 0001011                      (D) 1011010

**Key:** (B)

**Sol:** We can use a property of linear systematic code that any addition of any two code word will result in a new code word

$$\Rightarrow C_2 = C_1 + C_0 \text{ (Binary addition)}$$

$$\Rightarrow C_4 = C_3 + C_2$$

$$\Rightarrow C_4 = C_3 + C_1 + C_0$$

Using this XOR (0101100, 0011110, 1000110) = 0110100

24. A sinusoidal message signal having root mean square value of 4V and frequency of 1 kHz fed to a phase modulator with phase deviation constant 2 rad/volt. If the carrier signal is  $c(t) = 2\cos(2\pi 10^6 t)$ , the maximum instantaneous frequency of the phase modulated signal (rounded off to one decimal place) is \_\_\_\_\_ Hz.

**Key:** (1011312)

**Sol:**  $x_{pm}(t) = A_c \cos(2\pi f_c t + k_p m(t))$

Instantaneous phase  $\phi_i(t) = 2\pi f_c t + k_p m(t)$

Instantaneous frequency  $\omega_i(t) = 2\pi f_c + k_p \frac{d}{dt} m(t)$

Maximum instantaneous frequency (in Hz)

$$\begin{aligned}
 &= f_c + \frac{1}{2\pi} k_p \left( \frac{d}{d+} m(t) \right)_{\max} \\
 &= 1000 \times 10^3 + \frac{1}{2\pi} \times 2 \times 4\sqrt{2} \times 10^3 \\
 &= 1000 \times 10^3 + 11.312 \times 10^3 \\
 m(t) &= 4\sqrt{2} \sin(2\pi \times 10^3 t) = 1011312 \text{ Hz}
 \end{aligned}$$

25. If the vectors  $(1.0, -1.0, 2.0)$ ,  $(7.0, 3.0, x)$  and  $(2.0, 3.0, 1.0)$  in  $R^3$  are linearly dependent, the value of  $x$  is \_\_\_\_\_.

**Key:** (8)

**Sol:** Let  $X_1 = (1.0, -1.0, 2.0)$ ,  $X_2 = (7.0, 3.0, x)$  and  $X_3 = (2.0, 3.0, 1.0)$  be three given vectors. Consider these vectors as rows in a matrix  $A$ . For linearly dependent vectors, we have

$$\begin{aligned}
 |A| = 0 &\Rightarrow \begin{vmatrix} 1 & -1 & 2 \\ 7 & 3 & x \\ 2 & 3 & 1 \end{vmatrix} = 0 \\
 &\Rightarrow 1 \times (3 - 3x) + 1 \times (7 - 2x) + 2 \times (21 - 6) = 0 \\
 &\Rightarrow -5x + 40 = 0 \Rightarrow x = 8
 \end{aligned}$$

**Q.No. 26-55 Carry two Marks Each**

26. The autocorrelation function  $R_x(\tau)$  of a wide-sense stationary random process  $X(t)$  is shown in the figure.

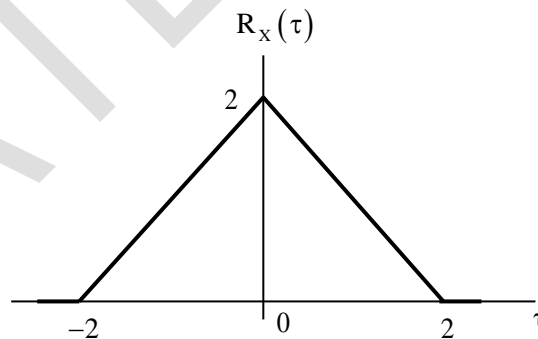

The average power of  $X(t)$  is \_\_\_\_\_.

**Key:** (2)

**Sol:** Average power of  $x(t) = E[x^2(t)] = R_x(0) = 2$

27. Consider the circuit shown in the figure.

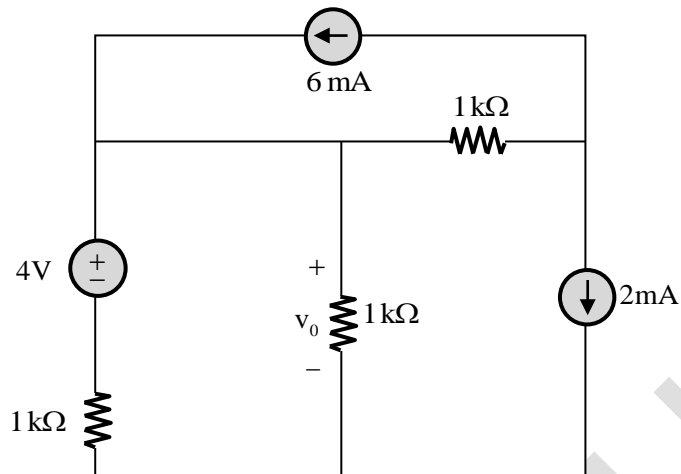

The value of  $v_0$  (rounded off to one decimal place) is \_\_\_\_\_ V.

**Key:** (1)

**Sol:** In the following network we need to find  $V_0$

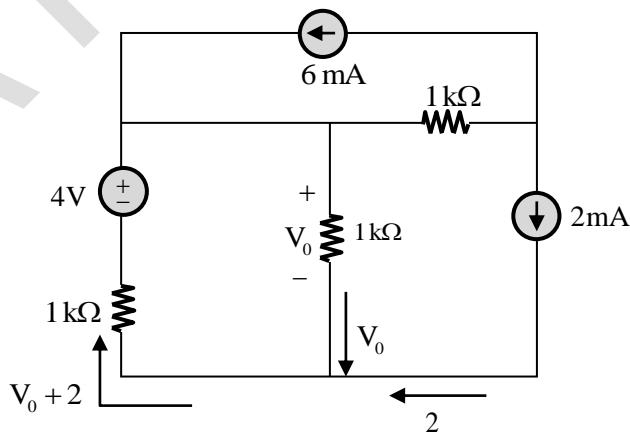
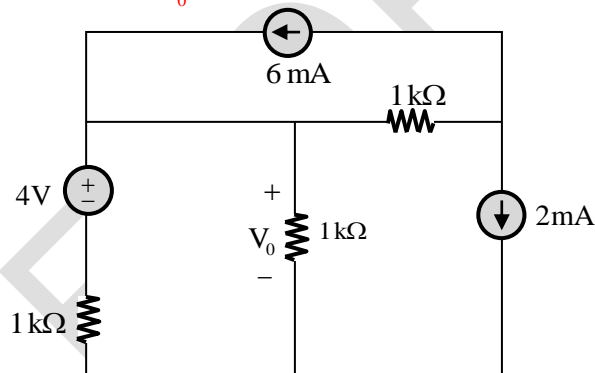

By KVL

$$4 - V_0 - (V_0 + 2) = 0$$

$$4 - V_0 - V_0 - 2 = 0$$

$$2V_0 = 2$$

$$\Rightarrow V_0 = 1V$$

28. Consider the signals  $x[n] = 2^{n-1}u[-n+2]$  and  $y[n] = 2^{-n+2}u[n+1]$ , where  $u[n]$  is the unit step sequence. Let  $X(e^{j\omega})$  and  $Y(e^{j\omega})$  be the discrete-time Fourier transform of  $x[n]$  and  $y[n]$ , respectively. The value of the integral

$$\frac{1}{2\pi} \int_0^{2\pi} X(e^{j\omega}) Y(e^{-j\omega}) d\omega$$

(rounded off to one decimal place) is \_\_\_\_\_.

**Key:** (8)

**Sol:** It is given that

$$x(n) = 2^{n-1}u(-n+2)$$

$$y(n) = 2^{-n+2}u(n+1)$$

We need to evaluate  $\frac{1}{2\pi} \int_0^{2\pi} X(e^{j\omega}) Y(e^{-j\omega}) d\omega$

$$\text{Let } P(e^{j\omega}) = X(e^{j\omega}) Y(e^{-j\omega})$$

$$\text{Then } \frac{1}{2\pi} \int_0^{2\pi} P(e^{j\omega}) d\omega = P(0) = P(n) \Big|_{n=0}$$

$$\{ P(n) = \frac{1}{2\pi} \int_0^{2\pi} P(e^{j\omega}) e^{-j\omega n} d\omega$$

$$\text{If we make } n = 0 \text{ in above equation then } P(0) = \frac{1}{2\pi} \int_0^{2\pi} P(e^{j\omega}) d\omega \}$$

$$\text{If } P(e^{j\omega}) = X(e^{j\omega}) Y(e^{-j\omega})$$

$$\text{Then } P(n) = x(n) * y(-n) \quad [ \because y(-n) \leftrightarrow Y(e^{-j\omega}) ]$$

$$P(n) = x(n) * g(n) \quad [ \text{Where } g(n) = y(-n) ]$$

$$= \sum_{k=-\infty}^{\infty} x(k) g(n-k) \quad [ g(n) = 2^{n+2}u(-n+1) ]$$

$$= \sum_{k=-\infty}^{\infty} [ 2^{k-1}u(-k+2) ] [ 2^{n-k+2}u[-(n-k)+1] ]$$

$$= \sum_{k=-\infty}^{\infty} (2^{k-1})(2^{n-k+2})u(-k+2)u(k-n+1)$$

$$\Rightarrow P(0) = \sum_{k=-\infty}^{\infty} 2^{k-1} \cdot 2^{-k+2} [ u(-k+2) \cdot u(k+1) ]$$

$$\left[ \begin{array}{l} u(-k+2) = 1; -\infty \leq k \leq 2 \\ u(k+1) = 1; -1 \leq k \leq \infty \\ u(-k+2) \cdot u(k+1) = \begin{cases} 1; & -1 \leq k \leq 2 \\ 0; & \text{else} \end{cases} \end{array} \right]$$

$$\begin{aligned} \Rightarrow P(0) &= \sum_{k=-1}^2 2^{k-1+(-k+2)} = \sum_{k=-1}^2 2 \\ &= \sum_{k=-1}^2 2(1)^k = 2(1)^{-1} + 2(1)^0 + 2(1)^1 + 2(1)^2 \\ &= (2 \times 1) + (2 \times 1) + (2 \times 1) + (2 \times 1) = 2 + 2 + 2 + 2 = 8 \end{aligned}$$

29. If  $(1235)_x = (3033)_y$ , where x and y indicate the bases of the corresponding numbers, then

(A)  $x = 9$  and  $y = 7$

(B)  $x = 8$  and  $y = 6$

(C)  $x = 7$  and  $y = 5$

(D)  $x = 6$  and  $y = 4$

**Key:** (B)

**Sol:** It is given that  $(1235)_x = (3033)_y$ , we need to get x, y

Converting both side into base 10

$$(1 \times x^3) + (2 \times x^2) + (3 \times x^1) + (5 \times x^0) = (3 \times y^3) + (0 \times y^2) + (3 \times y^1) + (3 \times y^0)$$

$$\Rightarrow x^3 + 2x^2 + 3x + 5 = 3y^3 + 3y + 3$$

Checking with option A i.e.,  $x = 9, y = 7$

$$9^3 + (2 \times 9^2) + (3 \times 9) + 5 = (3 \times 7^3) + (3 \times 7) + 3$$

$$\Rightarrow 923 = 1053 \text{ (invalid)}$$

Checking with option B i.e.,  $x = 8, y = 6$

$$8^3 + (2 \times 8^2) + (3 \times 8) + 5 = (3 \times 6^3) + (3 \times 6) + 3$$

$$\Rightarrow 669 = 669 \text{ (valid)}$$

No need to check C, D as B is already valid.

30. A silicon P-N junction is shown in the figure. The doping in the P region is  $5 \times 10^{16} \text{ cm}^{-3}$  and doping in the N region is  $10 \times 10^{16} \text{ cm}^{-3}$ . The parameters given are

Build-in voltage  $(\phi_{bi}) = 0.8 \text{ V}$

Electron charge  $(q) = 1.6 \times 10^{-19} \text{ C}$

Vacuum permittivity ( $\epsilon_0$ ) =  $8.85 \times 10^{-12}$  F/m

Relative permittivity of silicon ( $\epsilon_{Si}$ ) = 12

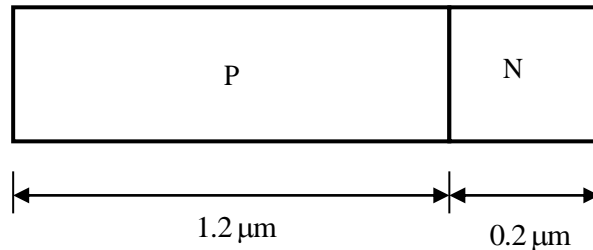

The magnitude of reverse bias voltage that would completely deplete one of the two regions (P or N) prior to the other (rounded off to one decimal place) is \_\_\_\_\_ V.

**Key:** (8.23)

**Sol:**

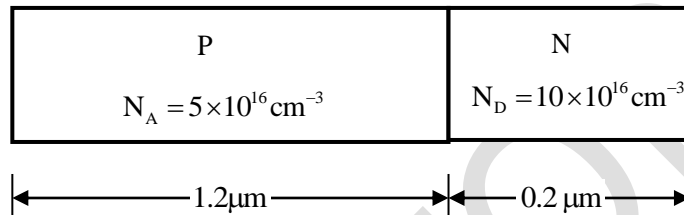

As per the junction law

$$\frac{W_p}{W_n} = \frac{N_D}{N_A} = \frac{10 \times 10^{16}}{5 \times 10^{16}} = 2$$

$$W_p = 2W_n$$

This indicates that, N-region will be depleted entirely at first

$$W = W_p + W_n = 2W_n + W_n = 3W_n = 3 \times 0.2 \mu\text{m}$$

$$\therefore W = 0.6 \mu\text{m} = 0.6 \times 10^{-4} \text{ cm}$$

$$W = \sqrt{\left(\frac{2\epsilon}{q}\right) \left(\frac{1}{N_A} + \frac{1}{N_D}\right) \cdot V_j} \quad (\text{where } V_j = V_{bi} + V_{RB})$$

$$= \sqrt{\left(\frac{2\epsilon}{q}\right) \left(\frac{1}{N_A} + \frac{1}{N_D}\right) (V_{bi} + V_{RB})}$$

$$V_{RB} = \frac{W^2 q \times N_A \cdot N_D}{2\epsilon (N_A + N_D)} - V_{bi}$$

$$V_{RB} = \frac{(0.6 \times 10^{-4})^2 \times 1.6 \times 10^{-19} \times 5 \times 10^{16} \times 10 \times 10^{16}}{2 \times 12 \times 8.85 \times 10^{-14} (5 \times 10^{16} + 10 \times 10^{16})} - 0.8 \text{ V} = 9.03 \text{ V} - 0.8 \text{ V} = 8.23 \text{ V}$$

$$\therefore V_{RB} = 8.23 \text{ V}$$

31. Addressing of a  $32K \times 16$  memory is realized using a single decoder. The minimum number of AND gates required for the decoder is  
 (A)  $2^8$                       (B)  $2^{19}$                       (C)  $2^{15}$                       (D)  $2^{32}$

**Key:** (C)

**Sol:** Size of memory:  $32k \times 16 = 2^5 \times 2^{10} \times 16 = 2^{15} \times 16 = 2^p \times n$

Here number of address line =  $p = 15$

15 address line can generate  $2^{15}$  number of different address, and each of these address will be accessed through output of decoder, so the size of decoder needed is  $15 \times 2^{15}$  which needs  $2^{15}$  number of AND gates.

In a  $2 \times 4$  Decoder the internal structure is

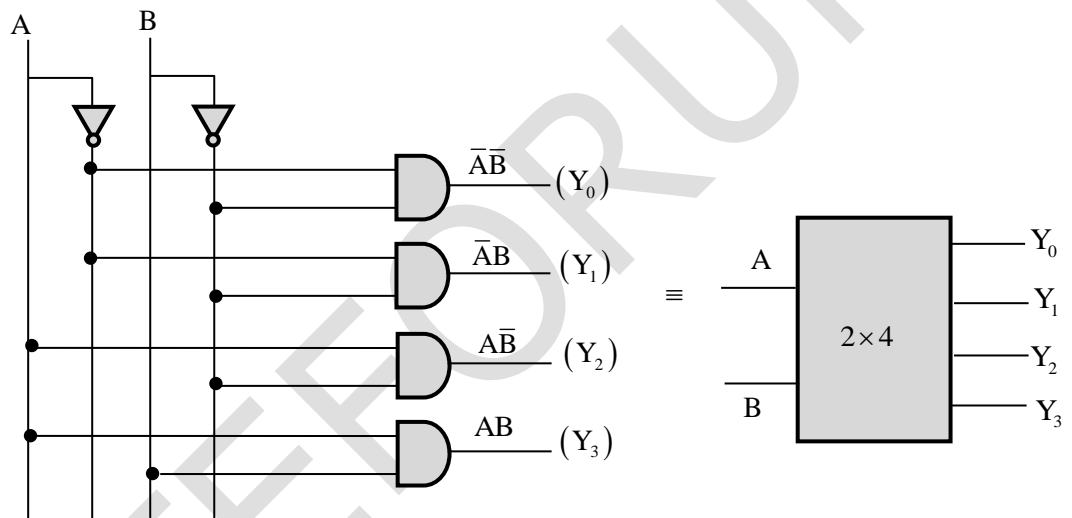

So, a  $2 \times 4$  decoder need 4 AND gates.

$2 \times 2^{15}$  decoders need  $2^{15}$  AND gates.

Basically, number of AND gate needed for a decoder is equal to number of output lines of decoder.

32. The impedance matching network shown in the figure is to match a lossless line having characteristics impedance  $Z_0 = 50\Omega$  with a load impedance  $Z_L$ . A quarter-wave line having a characteristic impedance  $Z_1 = 75\Omega$  is connected to  $Z_L$ . Two stubs having characteristic impedance of  $75\Omega$  each are connected to this quarter-wave line. One is a short-circuited (S.C) stub of length  $0.25\lambda$  connected across PQ and the other one is an open-circuited (O.C) stub of length  $0.5\lambda$  connected across RS.

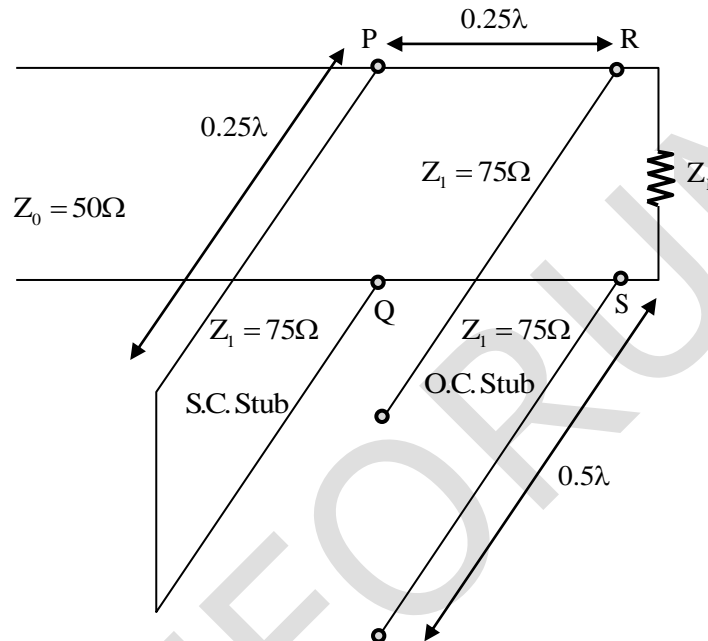

The impedance matching is achieved when the real part of  $Z_L$  is

- (A)  $33.3\Omega$       (B)  $50.0\Omega$       (C)  $75.0\Omega$       (D)  $112.5\Omega$

**Key:** (D)

**Sol:** Impedance across RS =  $Z_L \parallel \infty = Z_L$

$$\text{Load impedance across PQ} = \frac{Z_0^2}{0} \parallel \frac{(75)^2}{Z_L} = \infty \parallel \frac{(75)^2}{Z_L} = \frac{(75)^2}{Z_L}$$

$$\text{For matching } 50\Omega = \frac{(75)^2}{Z_L} \Rightarrow Z_L = 112.5$$

33. Consider the differential equation given below.

$$\frac{dy}{dx} + \frac{x}{1-x^2}y = x\sqrt{y}$$

The integrating factor of the differential equation is

- (A)  $(1-x^2)^{-1/4}$       (B)  $(1-x^2)^{-3/4}$       (C)  $(1-x^2)^{-1/2}$       (D)  $(1-x^2)^{-3/2}$

**Key:** (A)

**Sol:**  $\frac{dy}{dx} + \underbrace{\left(\frac{x}{1-x^2}\right)}_p y = \underbrace{(x)}_q y^{1/2}$  ... (1) is a Bernoulli's equation in y.

Dividing both sides by  $y^{1/2}$

$$y^{-1/2} \frac{dy}{dx} + \left(\frac{x}{1-x^2}\right)y^{1/2} = x \dots (2)$$

Put  $y^{1/2} = t \Rightarrow \frac{1}{2}y^{-1/2} \frac{dy}{dx} = \frac{dt}{dx}$

$\therefore$  (2) becomes  $2 \frac{dt}{dx} + \left(\frac{x}{1-x^2}\right)t = x$

$\Rightarrow \frac{dt}{dx} + \left(\frac{x}{2(1-x^2)}\right)t = \frac{x}{2}$  ... (3) is a linear equation in t.

$\therefore$  I.F =  $e^{\int \frac{x}{2(1-x^2)} dx} = e^{-\frac{1}{4} \int \frac{-2x}{1-x^2} dx} = e^{-\frac{1}{4} \ln(1-x^2)} = e^{\ln\left((1-x^2)^{-1/4}\right)} = (1-x^2)^{-1/4}$

34. In the circuit shown in the figure, the switch is closed at time  $t = 0$ , while the capacitor is initially charged to  $-5V$  (i.e.,  $v_c(0) = -5V$ ).

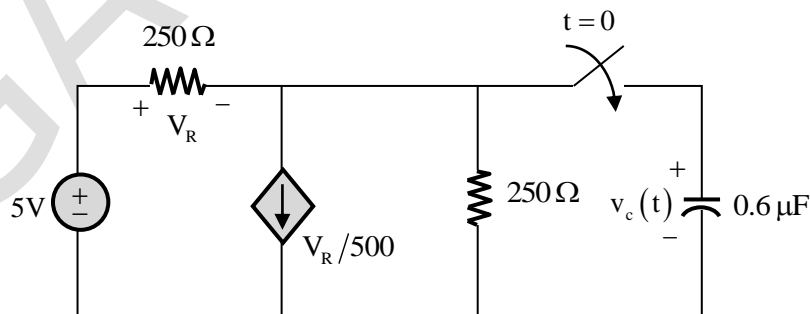

The time after which the voltage across the capacitor becomes zero (rounded off to three decimal places) is \_\_\_\_\_ms.

**Key:** (0.1389)

**Sol:** In the following network we need to find  $t$  at which capacitor voltage  $V_C(t)$  becomes 0 after switching.

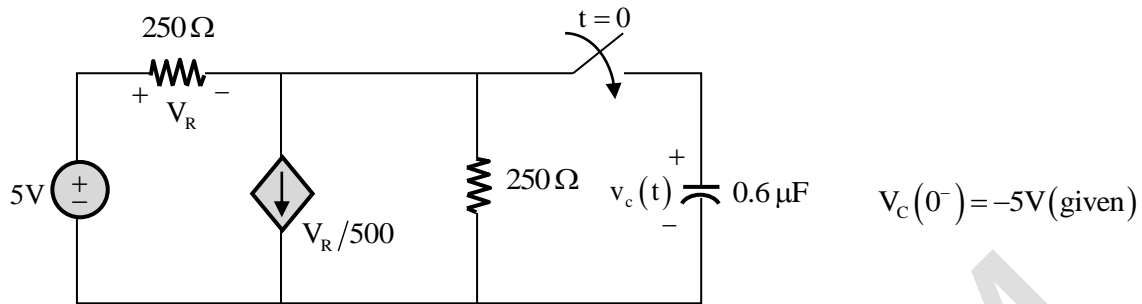

at  $t = \infty$  ————

- Switch is closed
- Capacitor is open circuit
- Network in steady state

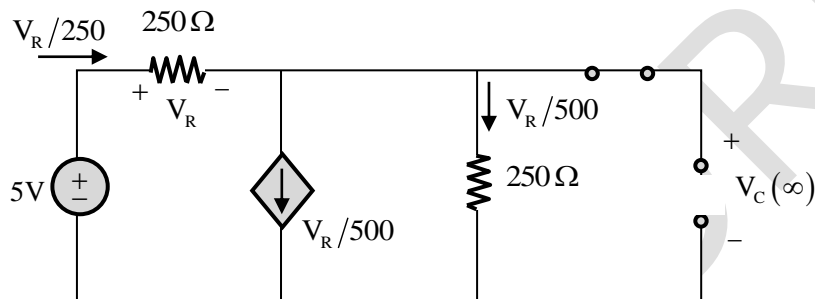

By KVL in outer loop

$$5 - V_R \left( \frac{V_R}{500} \times 250 \right) = 0$$

$$\Rightarrow 5 - V_R - \frac{V_R}{2} = 0$$

$$\Rightarrow \frac{3V_R}{2} = 5$$

$$\Rightarrow V_R = \frac{10}{3} \text{ V}$$

$$\Rightarrow V_C(\infty) = \frac{V_R}{500} \times 250 = \frac{V_R}{2} = \frac{10}{6} = \frac{5}{3} \text{ V} = 1.66 \text{ V}$$

Time constant  $\tau = R_{th}C$

$$R_{th} = \frac{V_{th}}{I_N}$$

- In the above circuit  $V_{th}$  and  $V_C(\infty)$  are same

$$\text{So } V_{th} = \frac{5}{3} \text{ V}$$

- Computation of  $I_N$

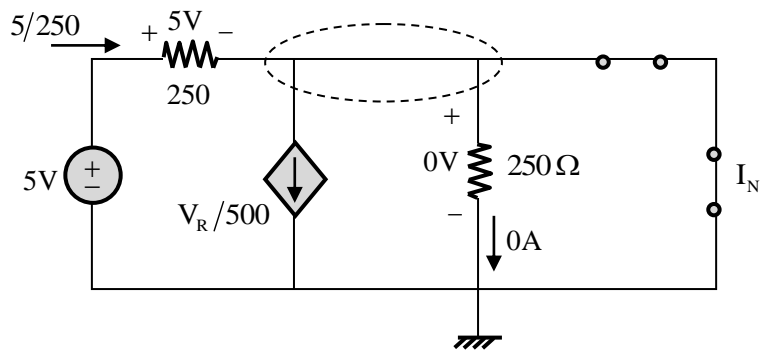

$$\text{By KCL } \frac{5}{250} = \frac{5}{500} + 0 + I_N$$

$$\Rightarrow I_N = \frac{5}{250} - \frac{5}{500} = \frac{1}{50} - \frac{1}{100} = \frac{2-1}{100} = \frac{1}{100} \text{ A}$$

$$R_{th} = \frac{V_{th}}{I_N} = \frac{5/3}{1/100} = \frac{500}{3} \Omega$$

$$\tau = R_{th}C = \frac{500}{3} \times 0.6 \times 10^{-6} = 1 \times 10^{-4} \text{ sec}$$

$$V_c(t) = V_c(\infty) + [V_c(0^-) - V_c(\infty)]e^{-t/\tau} = 1.66 + [-5 - 1.66]e^{-10^4 t}$$

$$\Rightarrow 0 = 1.66 - 6.66 e^{-10^4 t}$$

$$\Rightarrow e^{-10^4 t} = \frac{1.66}{6.66}$$

$$\Rightarrow -10^4 t = \ln\left(\frac{1.66}{6.66}\right)$$

$$\Rightarrow t = -10^{-4} \ln\left(\frac{1.66}{6.66}\right) = (-10^4)(1.389) = 1.389 \times 10^{-4} \text{ sec} = 0.138 \text{ msec}$$

35. The electrical system shown in the figure converts input source current  $i_s(t)$  to output voltage  $v_o(t)$ .

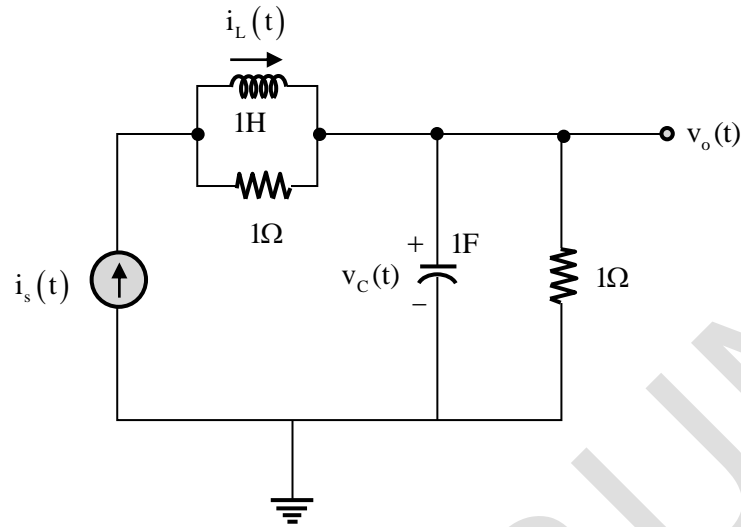

Current  $i_L(t)$  in the inductor and voltage  $v_C(t)$  across the capacitor are taken as the state variables, both assumed to be initially equal to zero, i.e.,  $i_L(0) = 0$  and  $v_C(0) = 0$ . The system is

- (A) completely state controllable but not observable
- (B) completely state controllable as well as completely observable
- (C) neither state controllable nor observable
- (D) completely observable but not state controllable

**Key:** (C)

**Sol:** Given that  $i_L(t)$  and  $V_C(t)$  are state variables

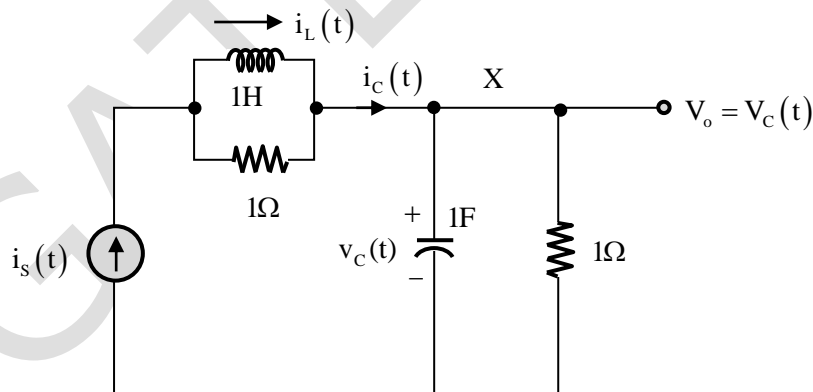

At node X by KCL

$$-i_s(t) + 1 \frac{dV_C(t)}{dt} + \frac{V_C(t)}{1} = 0$$

$$V_C'(t) = \frac{dV_C(t)}{dt} = i_s(t) - V_C(t)$$

By current-division principle

$$i_L(s) = \frac{i(s) \times 1}{s+1}$$

$$i_s(t) = \frac{di_L(t)}{dt} + i_L(t)$$

$$i_L(t) = \frac{di_L(t)}{d(t)} = i_s(t) - i_L(t)$$

State matrix A can be obtained by

$$\begin{bmatrix} i_L(t) \\ V_C(t) \end{bmatrix} = \begin{bmatrix} -1 & 0 \\ 0 & -1 \end{bmatrix} \begin{bmatrix} i_L(t) \\ V_C(t) \end{bmatrix} + \begin{bmatrix} 1 \\ 1 \end{bmatrix} i_s(t)$$

$$A = \begin{bmatrix} -1 & 0 \\ 0 & -1 \end{bmatrix} \quad B = \begin{bmatrix} 1 \\ 1 \end{bmatrix}$$

$$C = \text{controllability} = [B \quad AB] \quad AB = \begin{bmatrix} -1 & 0 \\ 0 & -1 \end{bmatrix} \begin{bmatrix} 1 \\ 1 \end{bmatrix} = \begin{bmatrix} -1 \\ -1 \end{bmatrix}$$

$$C = \begin{bmatrix} 1 & -1 \\ 1 & -1 \end{bmatrix}$$

$$|C| = \begin{vmatrix} 1 & -1 \\ 1 & -1 \end{vmatrix} = -1 + 1 = 0$$

$$\text{Observability} = 0 = \begin{bmatrix} C \\ CA \end{bmatrix}$$

$$\boxed{V_o(t) = V_C(t) + i_s(t)}$$

$$C = [0 \quad 1]$$

$$O = \begin{bmatrix} 0 & 1 \\ 0 & -1 \end{bmatrix}$$

$$C_A = [0 \quad 1] \begin{bmatrix} -1 & 0 \\ 0 & -1 \end{bmatrix} = [0 \quad -1]$$

$$|O| = 0$$

Answer 'C' system is neither state controllable non observable.

36. A real  $2 \times 2$  non-singular matrix A with repeated eigen value is given as

$$A = \begin{bmatrix} x & -3.0 \\ 3.0 & 4.0 \end{bmatrix}$$

Where x is a real positive number. The value of x (rounded off to one decimal place) is \_\_\_\_\_.

**Key: (10)**

**Sol:** The characteristic equation is  $\begin{vmatrix} x-\lambda & -3 \\ 3 & 4-\lambda \end{vmatrix} = 0$

$$\Rightarrow (x-\lambda)(4-\lambda) + 9 = 0$$

$$\Rightarrow \lambda^2 + (-4-x)\lambda + (4x+9) = 0, \text{ a quadratic equation in } \lambda$$

For repeated roots (eigen values), we have

$$B^2 - 4AC = 0, \text{ where } A = 1, B = -4-x, C = 4x+9$$

$$(-4-x)^2 - 4(1)(4x+9) = 0$$

$$16 + x^2 + 8x - 16x - 36 = 0$$

$$x^2 - 8x - 20 = 0$$

$$(x-10)(x+2) = 0$$

$$\Rightarrow x = 10 \text{ or } -2$$

Since x is positive

$$\therefore x = 10$$

37. The block diagram of a feedback system is shown in the figure.

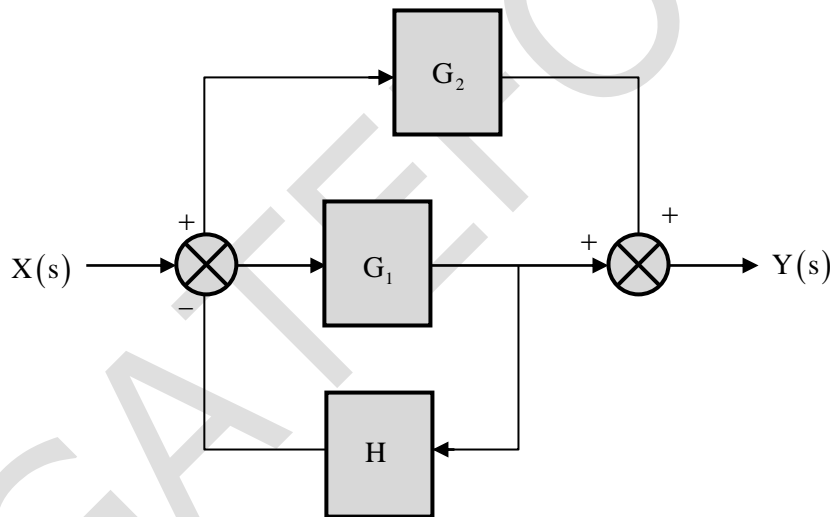

The transfer function  $\frac{Y(s)}{X(s)}$  of the system is

(A)  $\frac{G_1 + G_2 + G_1 G_2 H}{1 + G_1 H}$

(B)  $\frac{G_1 + G_2}{1 + G_1 H + G_2 H}$

(C)  $\frac{G_1 + G_2}{1 + G_1 H}$

(D)  $\frac{G_1 + G_2 + G_1 G_2 H}{1 + G_1 H + G_2 H}$

**Key:** (C)

**Sol:**

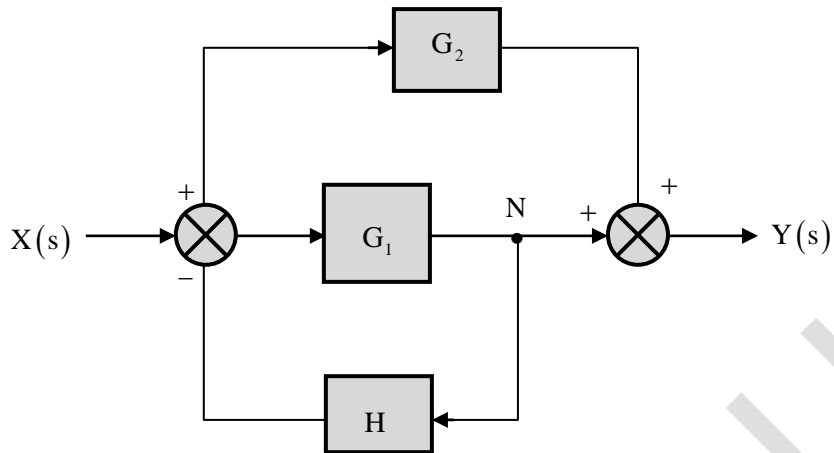

$$Y(s) = [X(s) - NH]G_2 + N$$

$$\text{Where } N = [X(s) - NH]G_1$$

$$N = X(s) \frac{G_1}{1 + G_1H}$$

$$Y(s) = G_2X(s) - NG_2H + N$$

$$Y(s) = G_2X(s) - \frac{X(s)G_1G_2H}{1 + G_1H} + X(s) \frac{G_1}{1 + G_1H}$$

$$Y(s) = X(s) \left[ \left[ \frac{G_2 + G_1G_2H - G_1G_2H}{1 + G_1H} \right] + \frac{G_1}{1 + G_1H} \right]$$

$$\frac{Y(s)}{X(s)} = \frac{G_1 + G_2}{1 + G_1H}$$

Hence option C is correct.

38. A speech signal, band limited to 4 kHz, is sampled at 1.25 times the Nyquist rate. The speech samples, assumed to be statistically independent and uniformly distributed in the range  $-5V$  to  $+5V$ , are subsequently quantized in an 8-bit uniform quantizer and then transmitted over a voice-grade AWGN telephone channel. If the ratio of transmitted signal power to channel noise power is 26 dB, the minimum channel bandwidth required to ensure reliable transmission of the signal with arbitrarily small probability of transmission error (rounded off to two decimal places) is \_\_\_\_\_ kHz.

**Key:** (9.25)

**Sol:** Using channel capacity relation for an AWGN channel

$$C = B \log_2 [1 + \text{SNR}]$$

$$\text{Data rate} = n.F_s = 8 \times 1.25 \times 2 \times 4000 = 80 \times 10^3 \text{ bits per record}$$

$$\Rightarrow \text{Data rate} \leq C$$

$$\Rightarrow 80 \times 10^3 \leq B \log_2 [1 + 400]$$

$$\Rightarrow B \geq \frac{80 \times 10^3}{\log_2 [401]} = \frac{80 \times 10^3}{8.64} = 9.25 \text{ kHz}$$

39. For an n-channel silicon MOSFET with 10 nm gate oxide thickness, the substrate sensitivity  $\left( \frac{\partial V_T}{\partial |V_{BS}|} \right)$  is found to be 50 mV/V at a substrate voltage  $|V_{BS}| = 2V$ , where  $V_T$  is the threshold voltage of the MOSFET. Assume that,  $|V_{BS}| \gg 2\phi_B$ , where  $q\phi_B$  is the separation between the Fermi energy level  $E_F$  and the intrinsic level  $E_i$  in the bulk. Parameters given are

$$\text{Electron charge } (q) = 1.6 \times 10^{-19} \text{ C}$$

$$\text{Vacuum permittivity } (\epsilon_0) = 8.85 \times 10^{-12} \text{ F/m}$$

$$\text{Relative permittivity of silicon } (\epsilon_{Si}) = 12$$

$$\text{Relative permittivity of oxide } (\epsilon_{ox}) = 4$$

The doping concentration of the substrate is

- (A)  $7.37 \times 10^{15} \text{ cm}^{-3}$  (B)  $4.37 \times 10^{15} \text{ cm}^{-3}$   
(C)  $2.37 \times 10^{15} \text{ cm}^{-3}$  (D)  $9.37 \times 10^{15} \text{ cm}^{-3}$

**Key:** (A)

**Sol:** For N-channel MOSFET their threshold voltage ( $V_T$ ) is given by

$$V_T = V_{T_0} + \gamma \left( \sqrt{|V_{BS}| + |2\phi_B|} - \sqrt{|2\phi_B|} \right)$$

Where,  $V_{T_0}$  threshold voltage no body-bias i.e.,  $|V_{BS}| = 0V$

$$\gamma = \frac{\sqrt{2\epsilon_s qN_a}}{\epsilon_{ox}} \dots (2) \quad (\because \text{N-channel MOSFET is having P-type substrate})$$

Differentiate equation (1) w.r.t  $V_{BS}$

$$\frac{\partial V_T}{\partial |V_{BS}|} = \frac{\gamma}{2\sqrt{|V_{BS}| + |2\phi_B|}} = 50 \text{ mV/V} \dots (3)$$

$$50 \times 10^{-3} v/v = \frac{\gamma}{2\sqrt{2}} \quad (\because |V_{BS}| \gg |2\phi_B|)$$

$$\gamma = 2\sqrt{2} \times 50 \times 10^{-3} = 0.141$$

From equation (3)

$$\gamma = \frac{\sqrt{2\epsilon_s qN_a}}{\epsilon_{ox}} = \frac{t_{ox}\sqrt{2\epsilon_s qN_a}}{\epsilon_{ox}}$$

$$\gamma = \frac{t_{ox}\sqrt{2\epsilon_s qN_a}}{\epsilon_{ox}} \dots (4)$$

Square on both the sides

$$\gamma^2 = \left(\frac{t_{ox}}{\epsilon_{ox}}\right)^2 \times 2\epsilon_s qN_a$$

$$\therefore N_a = \gamma^2 \left(\frac{\epsilon_{ox}}{t_{ox}}\right)^2 \times \frac{1}{2\epsilon_s q}$$

$$= (0.14)^2 \left(\frac{4 \times 8.854 \times 10^{-14}}{10 \times 10^{-9} \times 10^2}\right)^2 \times \frac{1}{2 \times 12 \times 8.854 \times 10^{-4} \times 1.6 \times 10^{-19}}$$

$$= \frac{2.491 \times 10^{-27}}{3.3984 \times 10^{-43}} = 7.329 \times 10^{15}$$

$$\therefore N_a = 7.37 \times 10^{15} \text{ cm}^{-3}$$

40. The propagation delay of the exclusive-OR (XOR) gate in the circuit in the figure is 3 ns. The propagation delay of all the flip-flops is assumed to be zero. The clock (Clk) frequency provided to the circuit is 500 MHz.

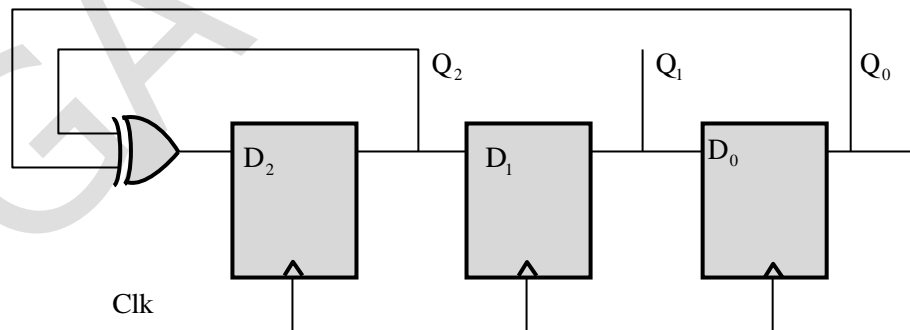

Starting from the initial value of the flip-flop outputs  $Q_2Q_1Q_0 = 111$  with  $D_2 = 1$ , the minimum number of triggering clock edges after which the flip-flop outputs  $Q_2Q_1Q_0$  becomes 100 (in integer) is \_\_\_\_\_.

**Key: (5)**

Sol: The given circuit is

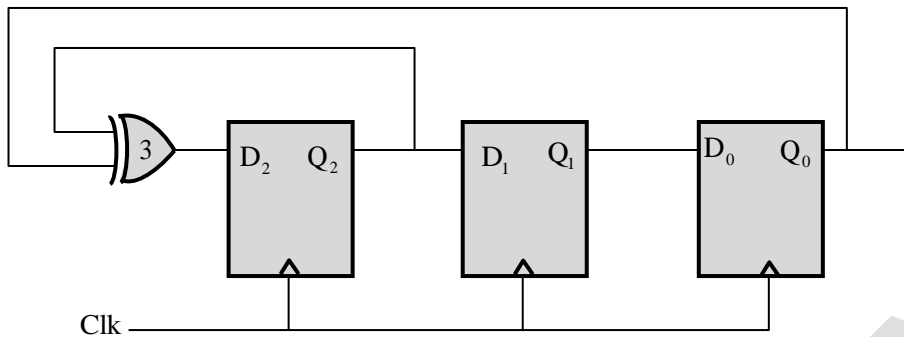

$$f_{\text{clk}} = 500\text{MHz}, T_{\text{clk}} = 2\text{nsec}$$

initially  $Q_2 Q_1 Q_0 = 111, D_2 = 1$

Delay of XOR gate is 3nsec.

We need to obtain after how many clock contents of  $Q_2 Q_1 Q_0$  becomes 100

Its clear from above circuit that  $Q_2^+ = D_2, Q_1^+ = D_1, Q_0^+ = D_0$

Let's draw the waveform's which will give a clear picture.

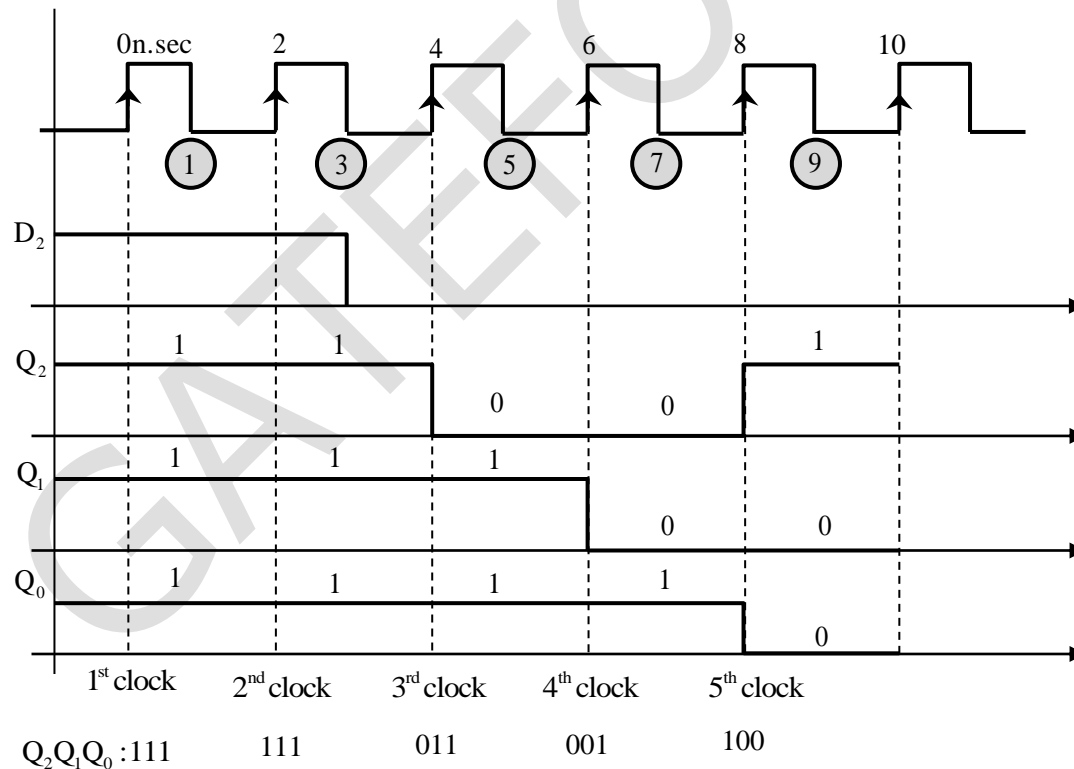

We can see after 5<sup>th</sup>clock content  $Q_2 Q_1 Q_0$  is 100

Note that XOR gate will change its output after 3nsec of its new input, which is happening here at 3nsec and 7nsec

41. Consider the circuit with an ideal OPAMP shown in the figure.

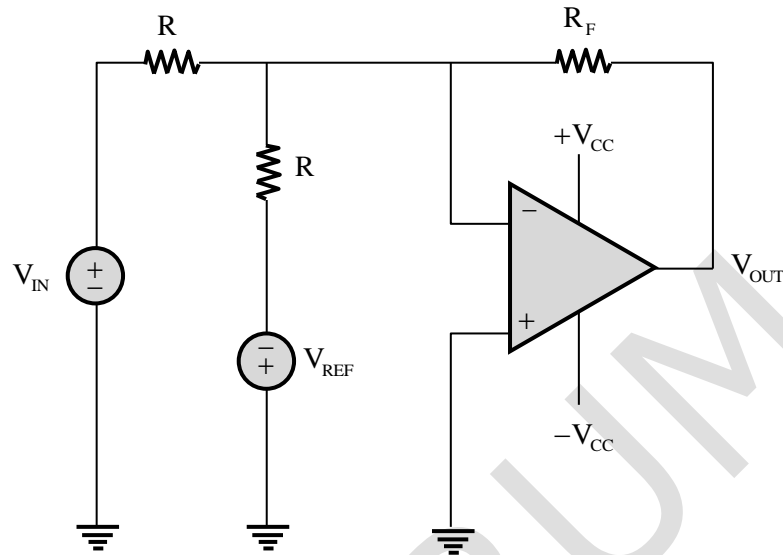

Assuming  $|V_{IN}| \ll |V_{CC}|$  and  $|V_{REF}| \ll |V_{CC}|$ , the condition at which  $V_{OUT}$  equals to zero is

- (A)  $V_{IN} = 0.5 V_{REF}$                       (B)  $V_{IN} = 2 + V_{REF}$   
 (C)  $V_{IN} = 2V_{REF}$                       (D)  $V_{IN} = V_{REF}$

**Key: (D)**

**Sol:**

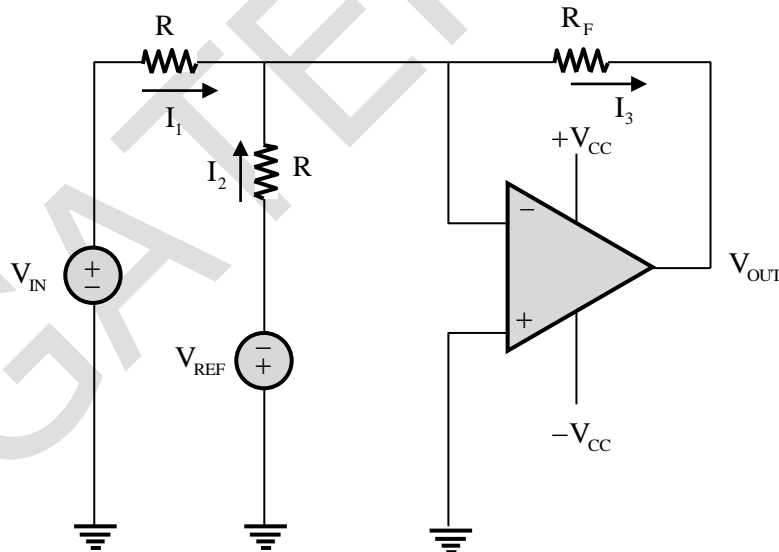

As per the virtual short concept of an ideal op-amp

$$V_+ = V_- = 0V$$

Apply KCL at node  $V_-$

$$I_1 + I_2 = I_3$$

$$\frac{V_{IN} - 0}{R} + \left( \frac{-V_{REF} - 0}{R} \right) = \frac{0 - V_{OUT}}{R_f}$$

For  $V_{OUT} = 0V$

$$\frac{V_{IN}}{R} - \frac{V_{REF}}{R} = 0$$

$$\therefore V_{IN} = V_{REF}$$

42. A bar of silicon is doped with boron concentration of  $10^{16} \text{ cm}^{-3}$  and assumed to be fully ionized. It is exposed to light such that electron-hole pairs are generated throughout the volume of the bar at the rate of  $10^{20} \text{ cm}^{-3} \text{ s}^{-1}$ . If the recombination lifetime is  $100 \mu\text{s}$ , intrinsic carrier concentration of silicon is  $10^{10} \text{ cm}^{-3}$  and assuming 100% ionization of boron, then the approximate product of steady-state electron and hole concentrations due to this light exposure is

- (A)  $10^{20} \text{ cm}^{-6}$       (B)  $2 \times 10^{20} \text{ cm}^{-6}$       (C)  $10^{32} \text{ cm}^{-6}$       (D)  $2 \times 10^{32} \text{ cm}^{-6}$

**Key:** (D)

**Sol:** Given data:  $P_o = 10^{16} \text{ cm}^{-3}$ ,  $\tau = 100 \mu\text{sec}$ ,  $n_i = 10^{10} \text{ cm}^{-3}$ ,  $g_o = 10^{20} \text{ cm}^{-3} \text{ s}^{-1}$

By using mass action law

$$n_o = \frac{n_i^2}{p_o} = \frac{10^{20}}{10^{16}} = 10^4 \text{ cm}^{-3}$$

Excess charge carrier:  $\Delta P = \Delta n = 10^{20} \text{ cm}^{-3} \text{ s}^{-1} \times 100 \times 10^{-6} \text{ s} = 10^{16} \text{ cm}^{-3}$

Product =  $(P_o + \Delta P)(n_o + \Delta n) = (10^{16} + 10^{16}) \times (10^4 + 10^{16}) = 2 \times 10^{32} \text{ cm}^{-6}$

$$\therefore \text{Product} = 2 \times 10^{32} \text{ cm}^{-6}$$

43. The content of the registers are  $R_1 = 25H$ ,  $R_2 = 30H$  and  $R_3 = 40H$ . The following machine instructions are executed.

PUSH{ $R_1$ }

PUSH{ $R_2$ }

PUSH{ $R_3$ }

POP{ $R_1$ }

POP{ $R_2$ }

POP{ $R_3$ }

After execution, the content of registers  $R_1, R_2, R_3$  are

- (A)  $R_1 = 30H, R_2 = 40H, R_3 = 25H$                       (B)  $R_1 = 25H, R_2 = 30H, R_3 = 40H$   
 (C)  $R_1 = 40H, R_2 = 30H, R_3 = 25H$                       (D)  $R_1 = 40H, R_2 = 25H, R_3 = 30H$

**Key:** (C)

**Sol:** It is given that content of Registers  $R_1 = 25H, R_2 = 30H, R_3 = 40H$

$PUSH \{R_1\} \rightarrow$  content of  $R_1$  will be pushed to top 2 bytes of stack

$PUSH \{R_2\} \rightarrow$  content of  $R_2$  will be pushed to top 2 bytes of stack

$PUSH \{R_3\} \rightarrow$  content of  $R_3$  will be pushed to top 2 bytes of stack

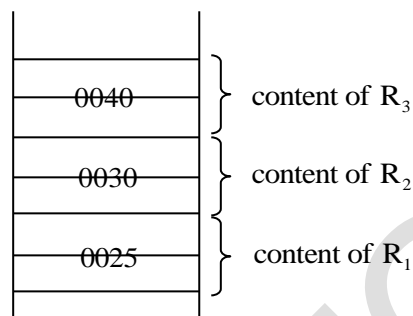

$POP R_1 \rightarrow$  Top 2 bytes of stack will be popped to  $R_1$ , So  $R_1 = 40$

$POP R_2 \rightarrow$  Top 2 bytes of stack will be popped to  $R_2$ , So  $R_2 = 30$

$POP R_3 \rightarrow$  Top 2 bytes of stack will be popped to  $R_3$ , So  $R_3 = 25$

Note: Register attached with PUSH, POP instruction one of always 16bit that is why 40 is written as 0040, 25 as 0025.....

- In every PUSH instruction execution content of register will be copied to top 2 bytes of stack and stack pointer content decrements by 2.
- In every pop instruction execution content of top 2 byte of stack memory will be copied to register and stack pointer content increments by 2.

So, after execution of above 6 instructions

$R_1 = 40, R_2 = 30, R_3 = 25$  .

44. An asymmetrical periodic pulse train  $v_{in}$  of 10V amplitude with on-time  $T_{ON} = 1 \text{ ms}$  and off-time  $T_{OFF} = 1 \mu\text{s}$  is applied to the circuit shown in the figure.

The diode  $D_1$  is ideal.

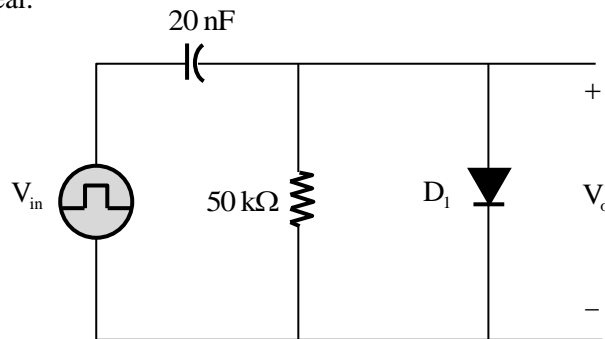

The difference between the maximum voltage and minimum voltage of the output waveform  $v_o$  (in integer) is \_\_\_\_\_ V.

**Key:** (10)

**Sol:**

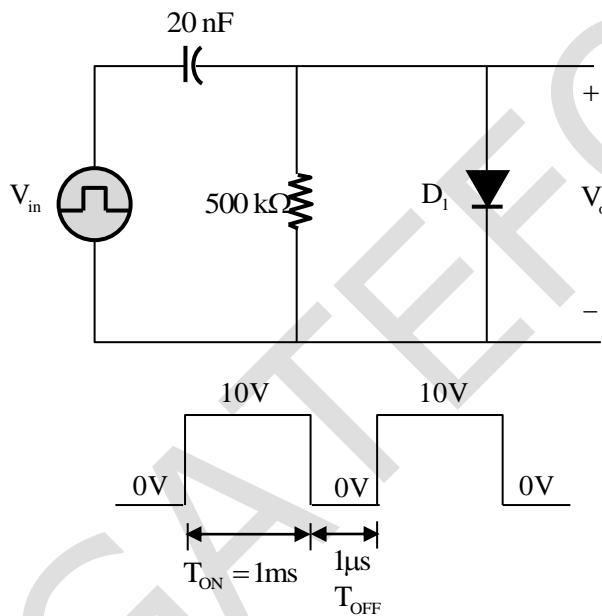

$$T = T_{ON} + T_{OFF} = 1.001 \text{ msec},$$

$$\tau = RC = 20 \times 10^{-9} \times 500 \times 10^3 = 10 \text{ ms}$$

So,  $\tau \gg T$

In  $T_{ON}$  duration diode be in conduction and their equivalent circuit is

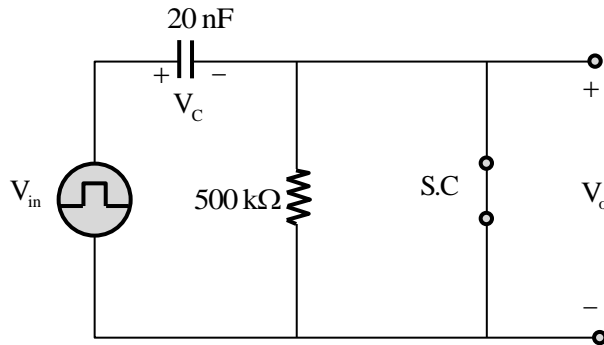

$$+V_{in} - V_c = 0V \Rightarrow V_c = V_{in} = +10V \text{ and } V_o = 0V$$

Once the capacitor is fully charged and  $\tau \gg T$ , so diode will not conduct further and their equivalent circuit is

$$+V_{in} - V_c - V_o = 0V$$

$$V_o = V_{in} - V_c$$

In steady state: when  $V_{in} = 10V$

$$V_o = 10V - 10V = 0V$$

When  $V_{in} = 0V$ , then

$$V_o = 0 - 10V$$

$$V_o = -10V$$

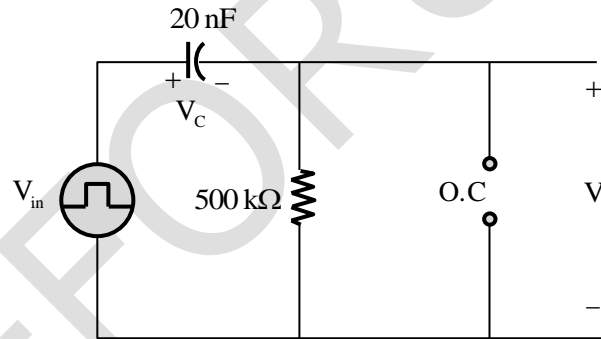

So, the output waveform in steady state is

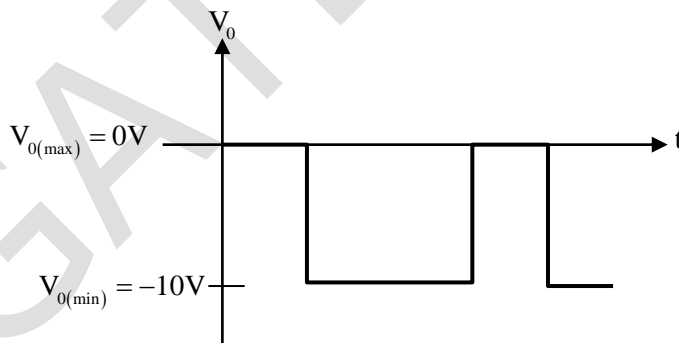

$$V_{o(\text{differential})} = V_{o(\text{max})} - V_{o(\text{min})} = 0V - (-10V) = 10V$$

45. The refractive indices of the core and cladding of an optical fiber are 1.50 and 1.48, respectively. The critical propagation angle, which is defined as the maximum angle that the light beam makes with the axis of the optical fiber to achieve the total internal reflection, (rounded off to two decimal places) is \_\_\_\_\_ degree.

**Key:** (9.36)

**Sol:** For total internal reflection angle of incidence  $= \sin^{-1}\left(\frac{1.48}{1.5}\right) = 80.63$

$\Rightarrow$  Angle it should make with air is  $= 90 - 80.63 = 9.36^\circ$

46. The circuit in the figure contains a current source driving a load having an inductor and a resistor in series, with a shunt capacitor across the load. The ammeter is assumed to have zero resistance. The switch is closed at time  $t = 0$ .

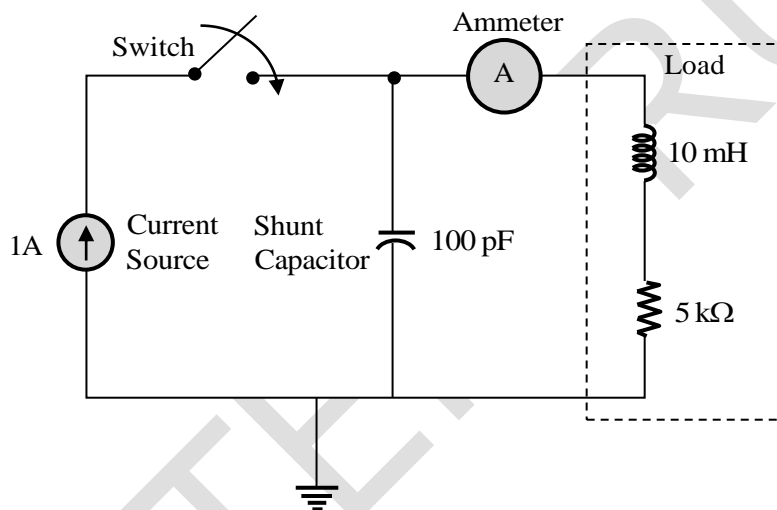

Initially, when the switch is open, the capacitor is discharged and the ammeter reads zero ampere. After the switch is closed, the ammeter reading keeps fluctuating for some time till it settles to a final steady value. The maximum ammeter reading that one will observe after the switch is closed (rounded off to two decimal places) is \_\_\_\_\_ A.

**Key:** (1.44)

**Sol:** In the following network we need to compute the peak value of current  $i(t)$

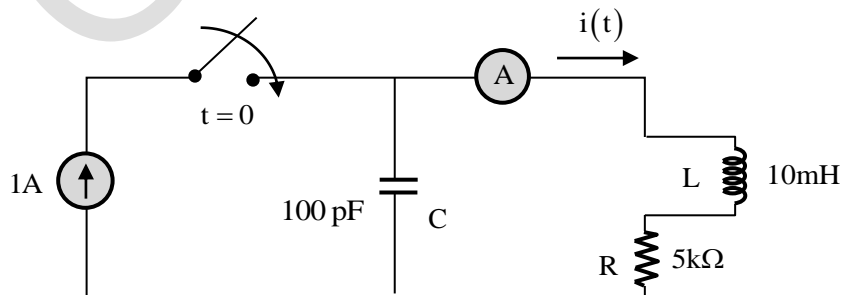

It is given that  $V_C(0^-) = 0V$

$$i_L(0^-) = 0A$$

In Laplace domain the above circuit for  $t > 0$  becomes

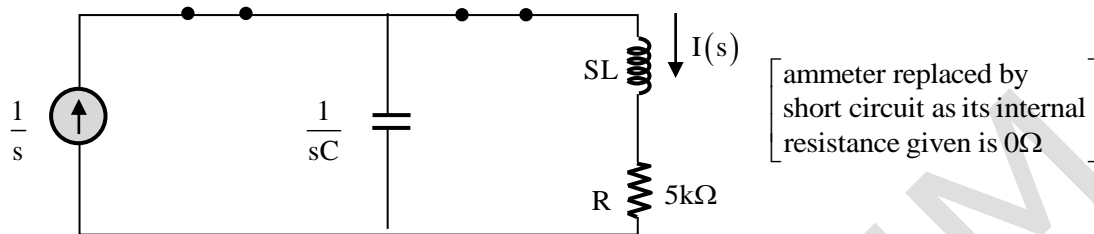

By current division rule

$$I(s) = \frac{1}{s} \frac{\frac{1}{sC}}{R + SL + \frac{1}{sC}} = \frac{1}{s(s^2LC + SCR + 1)} = \frac{\frac{1}{LC}}{s\left(s^2 + \frac{R}{L}s + \frac{1}{LC}\right)}$$

$$i(\infty) = \lim_{s \rightarrow \infty} sI(s) = 1$$

The expression of  $I(S)$  is identical to unit step response of a standard 2<sup>nd</sup> order closed loop system i.e.,

$$Y(s) = \frac{\omega_n^2}{s(s^2 + 2\xi\omega_n s + \omega_n^2)}$$

$$\text{By comparison } \omega_n = \frac{1}{\sqrt{LC}} = \frac{1}{\sqrt{10 \times 10^{-3} \times 100 \times 10^{-12}}} = 10^6 \text{ r/sec}$$

$$2\xi\omega_n = \frac{R}{L} \Rightarrow \xi = \frac{R}{2L\omega_n} = \frac{5 \times 10^3}{2 \times 10 \times 10^{-3} \times 10^6} = \frac{1}{4} = 0.25$$

$\xi = 0.25$ , underdamped response

$$\text{Overshoot} = e^{\frac{-\pi\xi}{\sqrt{1-\xi^2}}} = e^{\frac{-0.25\pi}{\sqrt{1-0.25^2}}} = 0.444$$

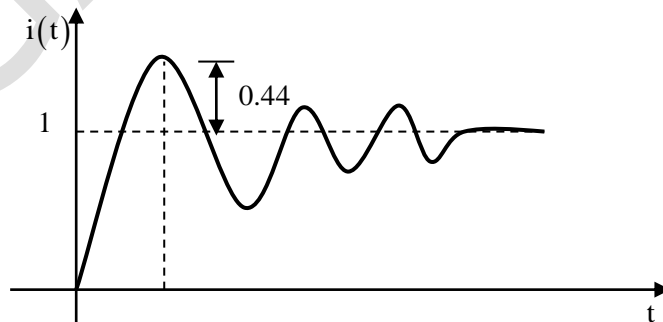

Since overshoot is 0.44, then the peak value is  $i(\infty) + 0.44 = 1 + 0.44 = 1.44A$

47. A 4 kHz sinusoidal message signal having amplitude 4V is fed to a delta modulator (DM) operating at a sampling rate of 32 kHz. The minimum step size required to avoid slope overload noise in the DM (rounded off to two decimal places) is \_\_\_\_\_ V.

**Key:** (3.14)

**Sol:** To avoid slope overload in DM

$$\Delta F_s \geq \left| \frac{d}{dt} m(t) \right|_{\max}$$

$$m(t) = 4 \sin(2\pi \times 4 \times 10^3 t)$$

$$F_s = 32 \text{ kHz}$$

$$\Rightarrow \Delta \cdot 32 \times 10^3 \geq 4 \times 4 \times 2\pi \times 10^3 t$$

$$\Rightarrow \Delta \geq \pi(3.14)$$

48. The vector function  $F(r) = -x\hat{i} + y\hat{j}$  is defines over a circular arc C shown in the figure.

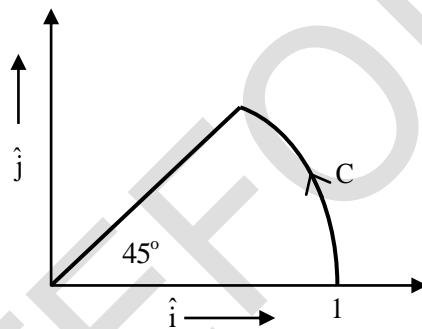

The line integral  $\int_C F(r) \cdot dr$  is

- (A)  $\frac{1}{4}$       (B)  $\frac{1}{3}$       (C)  $\frac{1}{2}$       (D)  $\frac{1}{6}$

**Key:** (C)

**Sol:** Parametric equations of the curve C (circular arc)  $x = \cos t$ ;  $y = \sin t$  where  $t$  is parameter with limits 0 to  $\frac{\pi}{4}$  and radius = 1

$$\begin{aligned} \therefore \int_C F(r) \cdot dr &= \int_C (-x dx + y dy) = \int_C \{(-\cos t)(-\sin t dt) + (\sin t)(\cos t dt)\} \\ &= \int_0^{\pi/4} 2 \sin t \cos t dt = \int_0^{\pi/4} \sin 2t dt \\ &= \left( \frac{-\cos 2t}{2} \right)_0^{\pi/4} = \frac{-1}{2}(0-1) = \frac{1}{2} \end{aligned}$$

49. The complete Nyquist plot of the open-loop transfer function  $G(s)H(s)$  of a feedback control system is shown in the figure.

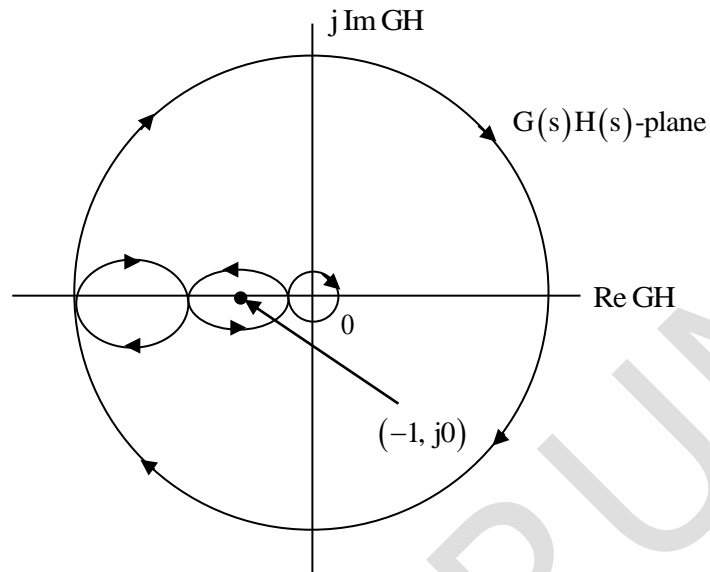

If  $G(s)H(s)$  has one zero in the right-half of the  $s$ -plane, the number of poles that the closed-loop system will have in the right-half of the  $s$ -plane is

- (A) 1                      (B) 3                      (C) 4                      (D) 0

**Key:** (D)

**Sol:** W.K. T,  $N = P - Z$

GH have no poles on the right half  $s$ -plane

$$P = 0$$

When  $(-1, +j0)$  lies at P then

$$N = -1 + 1 = 0 \text{ [One is clockwise and another anti-clock wise]}$$

$$N = P - Z$$

$$Z = 0 = \text{Closed loop poles}$$

$\therefore$  The system is stable.

Hence option 'D' is correct.

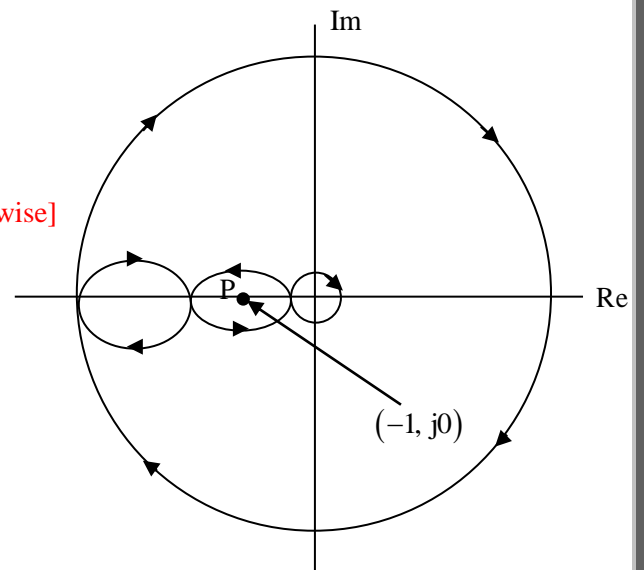

50. A unity feedback system that uses proportional-integral (PI) control is shown in the figure.

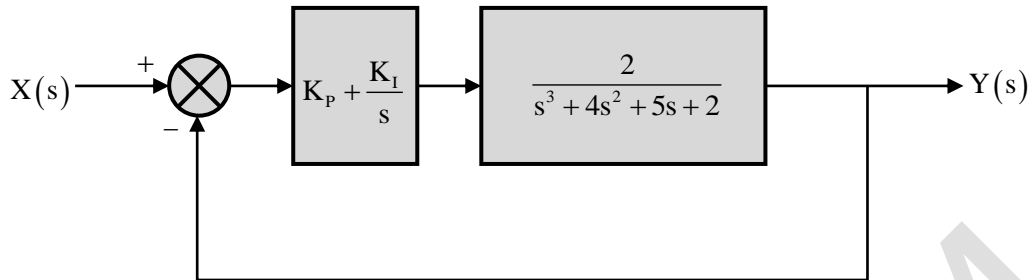

The stability of the overall system is controlled by tuning the PI control parameters  $K_p$  and  $K_i$ . The maximum value of  $K_i$  that can be chosen so as to keep the overall system stable or, in the worst case, marginally stable (rounded off to three decimal places) is \_\_\_\_\_.

**Key:** (0.5)

**Sol:** From block diagram:

$$G(s) = \left\{ k_p + \frac{k_i}{s} \right\} \left\{ \frac{2}{s^3 + 4s^2 + 5s + 2} \right\}$$

CE =  $1 + G(s) = 0$  characteristic equation

$$\frac{1 + 2(k_p s + k_i)}{s^4 + 4s^3 + 5s^2 + 2s} = 0$$

$$s^4 + 4s^3 + 5s^2 + 2s[1 + k_p] + 2k_i = 0$$

By R-H criteria

$$\begin{array}{r} s^4 \\ s^3 \end{array} \quad \begin{array}{r} 1 \\ 4 \end{array} \quad \begin{array}{r} 5 \\ 2[1 + k_p] \end{array} \quad \begin{array}{r} 2k_i \\ 0 \end{array}$$

$$s^2 \quad \frac{20 - 2[1 + k_p]}{4} \quad 2k_i$$

$$s^1 \quad x \quad 0$$

$$s^0 \quad 2k_i$$

$$\text{Where } x = \frac{[20 - 2[1 + k_p]]2[1 + k_p] - 8k_i}{4}$$

$$= 10[1 + k_p] - [1 + k_p] - 2k_i$$

$$= [1 + k_p][9 - k_p] - 2k_i$$

$$x = 9 + 8k_p - k_p^2 - 2k_i$$

One all system is stable only first column all coefficients should be possible (or) negative.

$$k_1 > 0, \quad 20 - [1 + k_p] > 0$$

$$1 + k_p < 10$$

$$k_p < 9$$

If  $k_p < 9$  system is unstable

$$x > 0 \quad 2k_1 > -(k_p^2 - 8k_p - 9)$$

$$2k_1 < (9 - k_p)(1 + k_p)$$

$x = 0$  marginal stable  $k_p = 9, k_p = -1$   $-1 < k_p < 9 \rightarrow$  stable

$k_p < 0.495$  maximum rate  $k_p = 0.5$

51. Consider the two-port network shown in the figure.

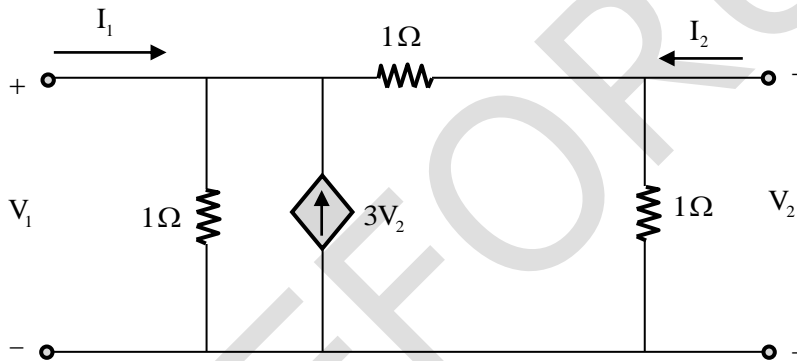

The admittance parameters, in siemens, are

(A)  $y_{11} = 2, y_{12} = -4, y_{21} = -1, y_{22} = 2$

(B)  $y_{11} = 1, y_{12} = -2, y_{21} = -1, y_{22} = 3$

(C)  $y_{11} = 2, y_{12} = -4, y_{21} = -4, y_{22} = 3$

(D)  $y_{11} = 2, y_{12} = -4, y_{21} = -4, y_{22} = 2$

**Key:** (A)

**Sol:** In the following network we need to compute Y parameter

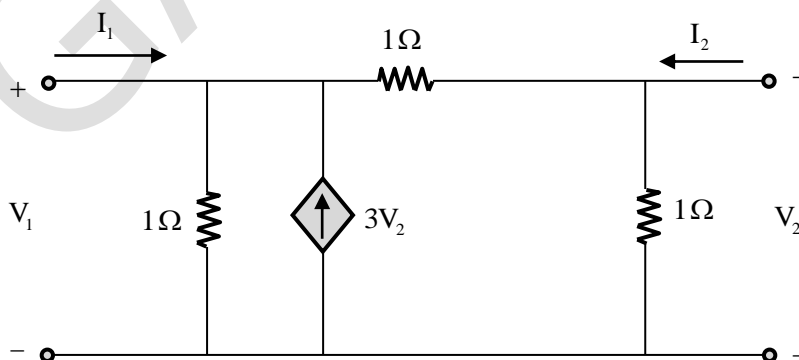

By nodal analysis at node 1

Node 1	Node 2
$-I_1 - 3V_2 + \frac{V_1}{1} + \frac{V_1 - V_2}{1} = 0$ $\Rightarrow I_1 = V_1 + V_1 - V_2 - 3V_2$ $\Rightarrow I_1 = 2V_1 - 4V_2$ $\Rightarrow I_1 = Y_{11}V_1 + Y_{12}V_2$ <p>So <math>Y_{11} = 2, Y_{12} = -4</math></p>	$-I_2 + \frac{V_1}{1} + \frac{V_2 - V_1}{1} = 0$ $\Rightarrow I_2 = -V_1 + V_2 + V_2$ $\Rightarrow I_2 = -V_1 + 2V_2$ $\Rightarrow I_2 = Y_{21}V_1 + Y_{22}V_2$ <p>So <math>Y_{21} = -1, Y_{22} = 2</math></p>

$$Y = \begin{bmatrix} 2 & -4 \\ -1 & 2 \end{bmatrix}$$

52. Consider two 16-point sequences  $x[n]$  and  $h[n]$ . Let the linear convolution of  $x[n]$  and  $h[n]$  be denoted by  $y[n]$ , while  $z[n]$  denotes the 16-point inverse discrete Fourier transform (IDFT) of the product of the 16-point DFTs of  $x[n]$  and  $h[n]$ . The value(s) of  $k$  for which  $z[k] = y[k]$  is/are
- (A)  $k = 0$  (B)  $k = 0, 1, 2, \dots, 15$   
 (C)  $k = 15$  (D)  $k = 0$  and  $k = 15$

**Key:** (C)

**Sol:** It is given that  $y(n) = x(n) * h(n)$

$$Z(n) = \text{IDFT} [X(k).H(k)]$$

16 point DFT is considered

We need to find for what value of  $k, y(k) = z(k)$

$$\text{IDFT} [X(k).H(k)] = x(n) \circledast h(n) \quad [\circledast: \text{circular convolution}]$$

$x(n)$  have 16 samples

$h(n)$  have 16 samples

Then  $x(n) * h(n)$  will have  $16 + 16 - 1 = 31$  number of samples  $x(n) \circledast h(n)$  will have 16 number of samples.

While computing circular convolution through linear convolution, we used to add last  $(k - 1)$  number of samples of linear convolution in beginning without disturbing the  $k$ th sample of linear and circular convolution. So the  $k^{\text{th}}$  samples of linear convolution and circular convolution same.

$$\text{For example, } x[n] = \begin{bmatrix} 1, 2, 3 \end{bmatrix}$$

$$h(n) = \begin{bmatrix} 4, 5, 6 \end{bmatrix}$$

$$\begin{array}{r}
 x(n) * h(n) \quad 1 \quad 2 \quad 3 \\
 \hline
 4 \quad 5 \quad 6 \\
 \hline
 4 \quad 8 \quad 12 \\
 \quad 5 \quad 10 \quad 15 \\
 \quad \quad 6 \quad 12 \quad 18 \\
 \hline
 4 \quad 13 \quad 28 \quad 27 \quad 18 \\
 27 \quad 28 \\
 \hline
 31 \quad 41 \quad 28
 \end{array}$$

$$\bullet y(n) = x(n) * h(n) = [4, 13, 28, 27, 18]$$

$$\bullet z(n) = x(n) \otimes h(n) = [31, 31, 28]$$

Here we have taken 3 samples in both  $x(n)$ ,  $h(n)$ , and can see the 3<sup>rd</sup> samples of  $y(n)$ ,  $z(n)$  are same i.e., 28. [3<sup>rd</sup> sample is equivalent to  $n = 2$  or  $k = 2$ ]

Instead of 3 samples, if we take 16 samples then 16<sup>th</sup> samples will appear same in both  $y(n)$ ,  $z(n)$

$$\left[ \begin{array}{l}
 16^{\text{th}} \text{ samples is equivalent to } n = 15 \text{ or } k = 15 \\
 \text{since starting value of } n/k \text{ is } 0 \text{ not } 1
 \end{array} \right]$$

53. Consider a rectangular coordinate system  $(x, y, z)$  with unit vectors  $a_x, a_y$  and  $a_z$ . A plane wave travelling in the region  $z \geq 0$  with electric field vector  $E = 10 \cos(2 \times 10^8 t + \beta z) a_y$  is incident normally on the plane at  $z = 0$ , where  $\beta$  is the phase constant. The region  $z \geq 0$  is in the free space and the region  $z < 0$  is filled with a lossless medium (permittivity  $\epsilon = \epsilon_0$ , permeability  $\mu = 4\mu_0$ , where  $\epsilon_0 = 8.85 \times 10^{-12}$  F/m and  $\mu_0 = 4\pi \times 10^{-7}$  H/m). The value of the reflection coefficient is

(A)  $\frac{3}{5}$

(B)  $\frac{1}{3}$

(C)  $\frac{2}{5}$

(D)  $\frac{2}{3}$

**Key:** (B)

**Sol:** Considering two medium

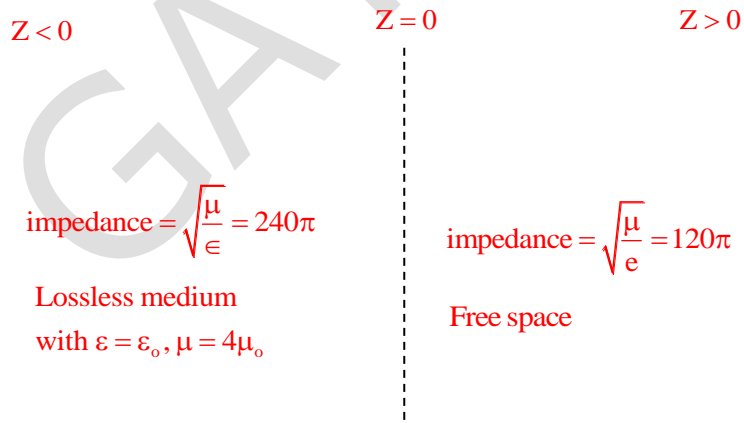

$$\Rightarrow \text{Reflection coefficient} = \frac{240\pi - 120\pi}{240\pi + 120\pi} = \frac{120\pi}{360\pi} = \frac{1}{3}$$

54. Consider the vector field  $F = a_x(4y - c_1z) + a_y(4x + 2z) + a_z(2y + z)$  in a rectangular coordinate system  $(x, y, z)$  with unit vectors  $a_x, a_y$  and  $a_z$ . If the field  $F$  is irrotational (conservative), then the constant  $c_1$  (in integer) is \_\_\_\_\_.

**Key:** (0)

**Sol:** For irrotational field, we have  $\text{curl}(F) = 0$

$$\Rightarrow \begin{vmatrix} a_x & a_y & a_z \\ \frac{\partial}{\partial x} & \frac{\partial}{\partial y} & \frac{\partial}{\partial z} \\ 4y - c_1z & 4x + 2z & 2y + z \end{vmatrix} = 0$$

$$\Rightarrow a_x(2 - z) - a_y(0 + c_1) + a_z(4 - 4) = 0$$

$$\Rightarrow c_1 = 0$$

55. Consider a superheterodyne receiver tuned to 600 kHz. If the total oscillator feeds a 1000 kHz signal to the mixer, the image frequency (in integer) is \_\_\_\_\_ kHz.

**Key:** (1400)

**Sol:**

